



US006666266B2

(12) **United States Patent**
Starr et al.

(10) **Patent No.:** **US 6,666,266 B2**
(45) **Date of Patent:** **Dec. 23, 2003**

(54) **SCREW-DRIVEN WELLHEAD ISOLATION TOOL**

(75) Inventors: **Phillip M. Starr, Duncan, OK (US); Don S. Folds, Duncan, OK (US); Lee Wayne Stepp, Comanche, OK (US)**

(73) Assignee: **Halliburton Energy Services, Inc., Duncan, OK (US)**

(*) Notice: Subject to any disclaimer, the term of this patent is extended or adjusted under 35 U.S.C. 154(b) by 0 days.

(21) Appl. No.: **10/138,544**

(22) Filed: **May 3, 2002**

(65) **Prior Publication Data**

US 2003/0205373 A1 Nov. 6, 2003

(51) **Int. Cl.**⁷ **E21B 19/00**

(52) **U.S. Cl.** **166/90.1; 166/85.4; 166/77.51**

(58) **Field of Search** **166/90.1, 70, 72, 166/77.4, 84.5, 85.4, 77.51, 85.1, 97.1**

(56) **References Cited**

U.S. PATENT DOCUMENTS

3,830,304 A *	8/1974	Cummins	166/305.1
4,023,814 A	5/1977	Pitts	277/181
4,111,261 A	9/1978	Oliver	166/86
4,262,743 A	4/1981	Surjaatmadja	166/91
4,315,543 A	2/1982	Luers et al.	166/202
4,341,264 A	7/1982	Cox et al.	166/55
4,487,025 A	12/1984	Hamid	62/54
4,612,984 A	9/1986	Crawford	166/77
4,657,075 A	4/1987	McLeod	166/72
4,682,657 A	7/1987	Crawford	166/385
4,691,770 A	9/1987	McLeod	166/73
4,867,243 A	9/1989	Garner et al.	66/379
4,991,650 A	2/1991	McLeod	166/72
4,993,488 A	2/1991	McLeod	166/72
4,993,489 A	2/1991	McLeod	166/72
5,012,865 A	5/1991	McLeod	166/90
5,025,857 A	6/1991	McLeod	166/77
5,060,723 A	10/1991	Sutherland et al.	166/202
5,113,936 A	5/1992	Sutherland	166/85

5,261,487 A	11/1993	McLeod et al.	166/77
5,285,852 A	2/1994	McLeod	166/379
5,332,044 A	7/1994	Dallas et al.	166/386
5,372,202 A	12/1994	Dallas	166/386
5,396,956 A	3/1995	Cherewyk et al.	166/250
5,429,191 A	7/1995	Schmidt et al.	166/297
5,540,282 A	7/1996	Dallas	166/379
5,605,194 A	2/1997	Smith	166/382
5,615,739 A	4/1997	Dallas	166/306
5,785,121 A	7/1998	Dallas	166/90.1
5,819,851 A	10/1998	Dallas	166/308
5,890,541 A	4/1999	Jennings et al.	166/336
5,927,403 A	7/1999	Dallas	166/77.51
5,975,211 A	11/1999	Harris	166/379
6,009,941 A	1/2000	Haynes	166/72
6,039,120 A	3/2000	Wilkins et al.	166/368
6,145,596 A	11/2000	Dallas	166/379
6,176,310 B1	1/2001	Smith et al.	166/89.1
6,179,053 B1	1/2001	Dallas	166/77.51
6,220,363 B1	4/2001	Dallas	166/382
6,234,253 B1	5/2001	Dallas	166/377
6,289,993 B1 *	9/2001	Dallas	166/386
6,364,024 B1 *	4/2002	Dallas	166/379
6,447,021 B1 *	9/2002	Haynes	285/302
6,557,629 B2 *	5/2003	Wong et al.	166/76.1

FOREIGN PATENT DOCUMENTS

EP 0 572 732 B1 8/1998

* cited by examiner

Primary Examiner—Roger Schoeppel

(74) Attorney, Agent, or Firm—John W. Wustenberg; Anthony L. Rahhal

(57) **ABSTRACT**

A wellhead isolation tool comprises a threaded drive rod coaxially aligned with a tubular mandrel having a smooth outer surface. A motor displaces the threaded drive rod vertically without rotating the drive rod to move the tubular mandrel through a wellhead into a tubular element in a well. The lower end of the tubular mandrel will sealably engage the tubular element in the well so that treating fluids or other substances such as, but not limited to, chemicals and erosive flows, can be displaced therethrough at high pressures into the well to fracture or otherwise treat the well without damaging the wellhead.

50 Claims, 16 Drawing Sheets

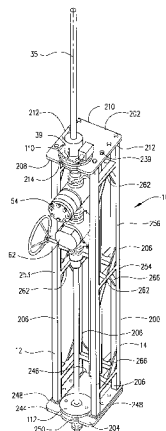

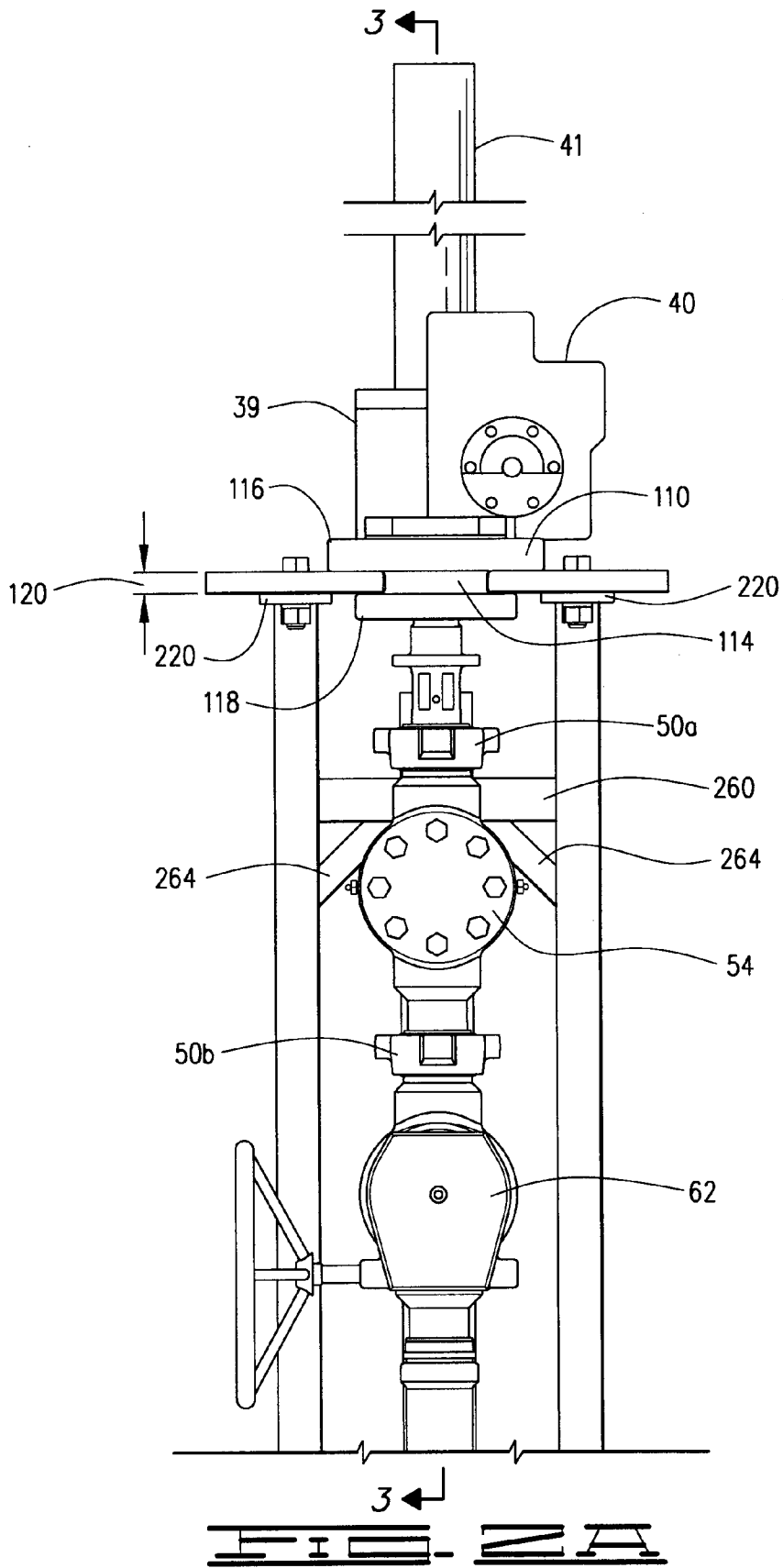

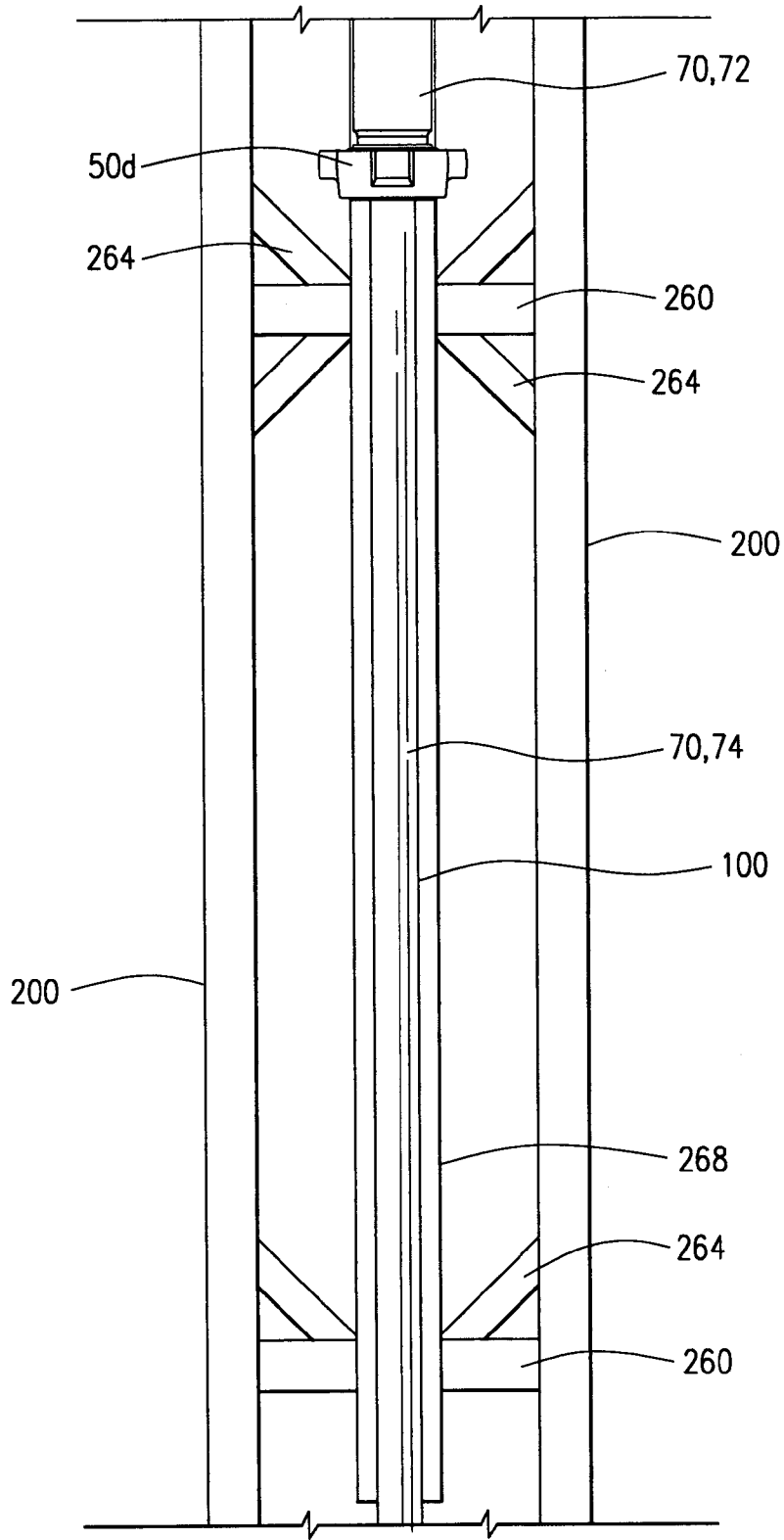

FIG. 2B

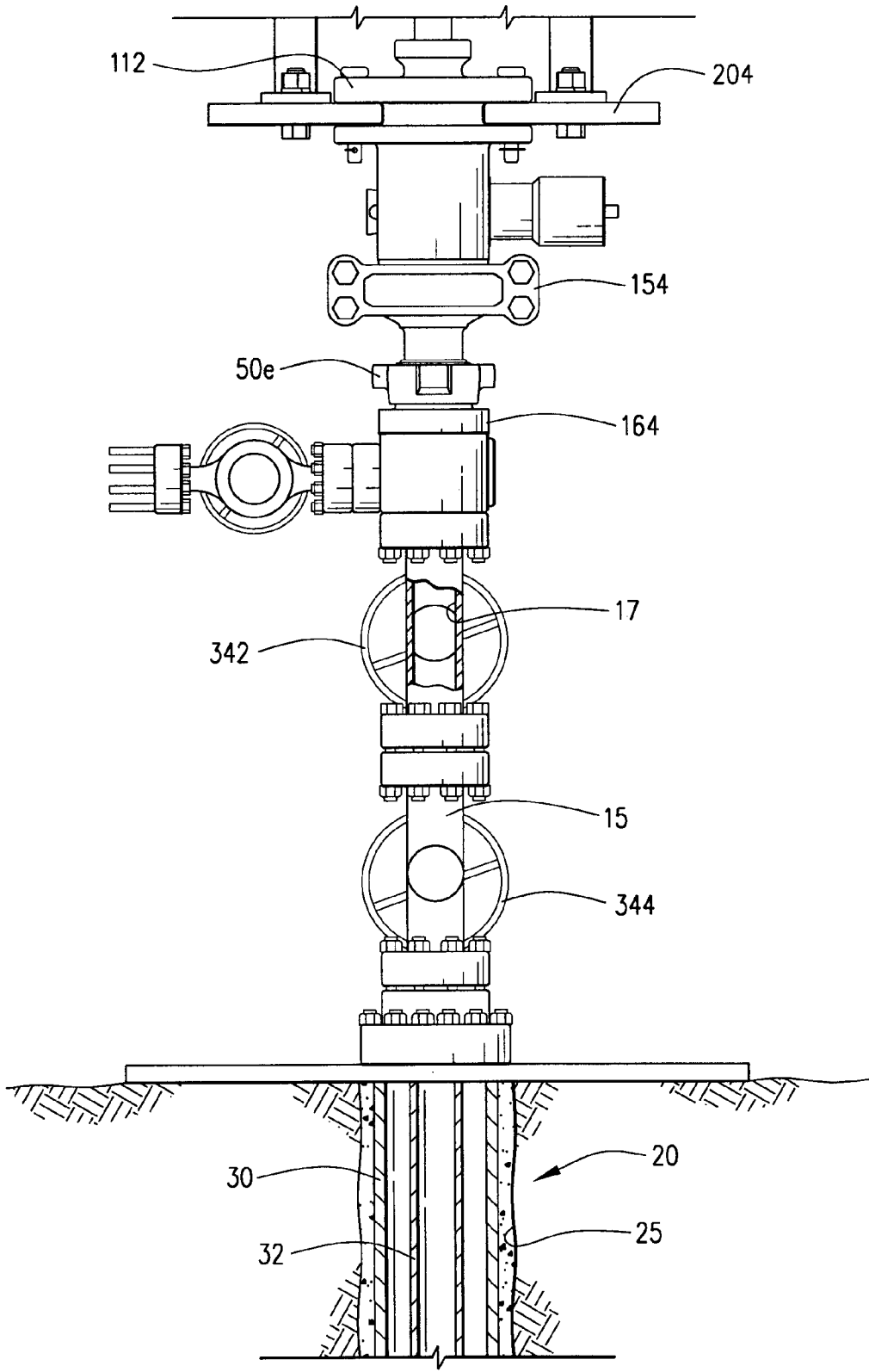

FIG. 20

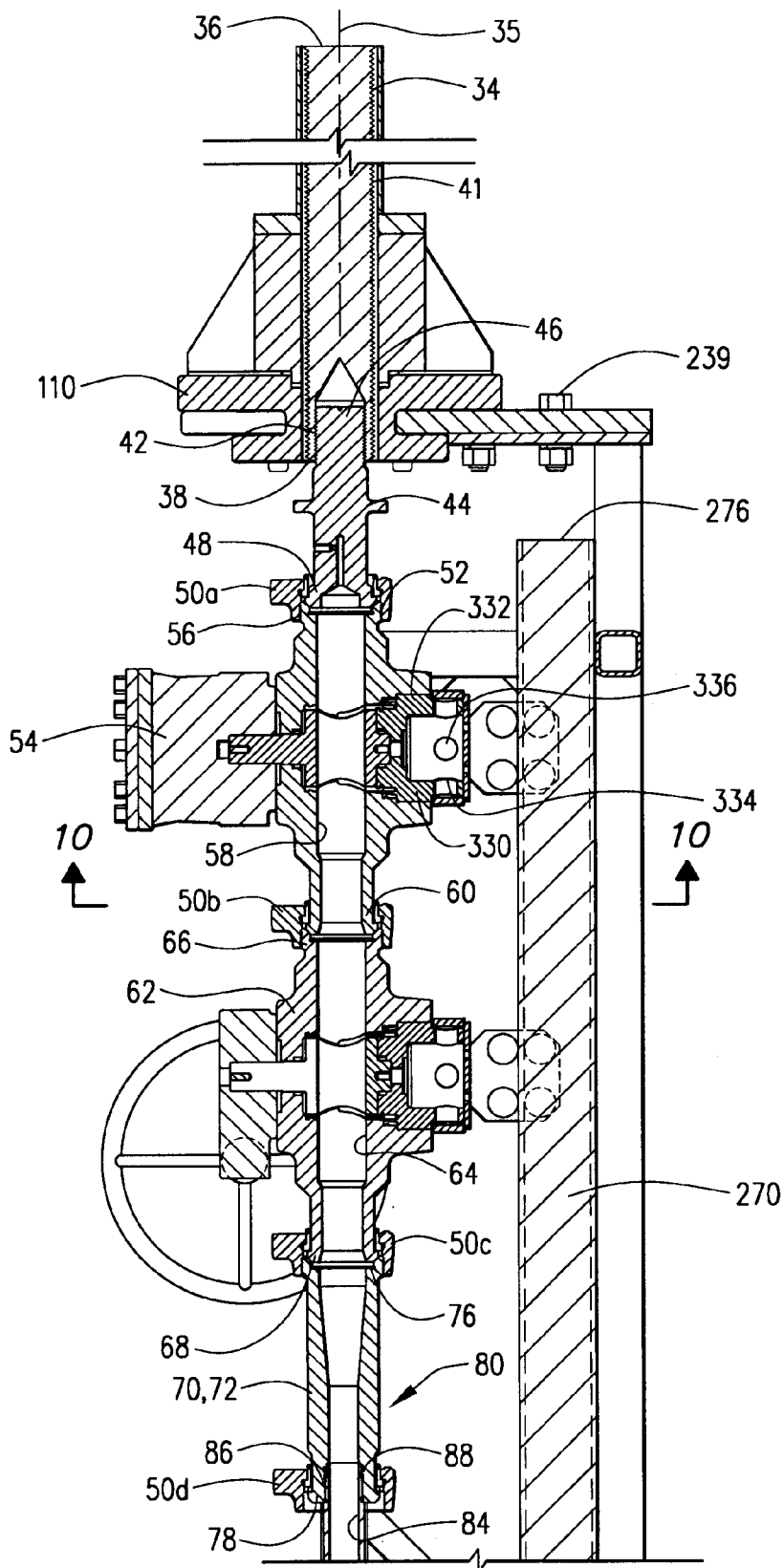
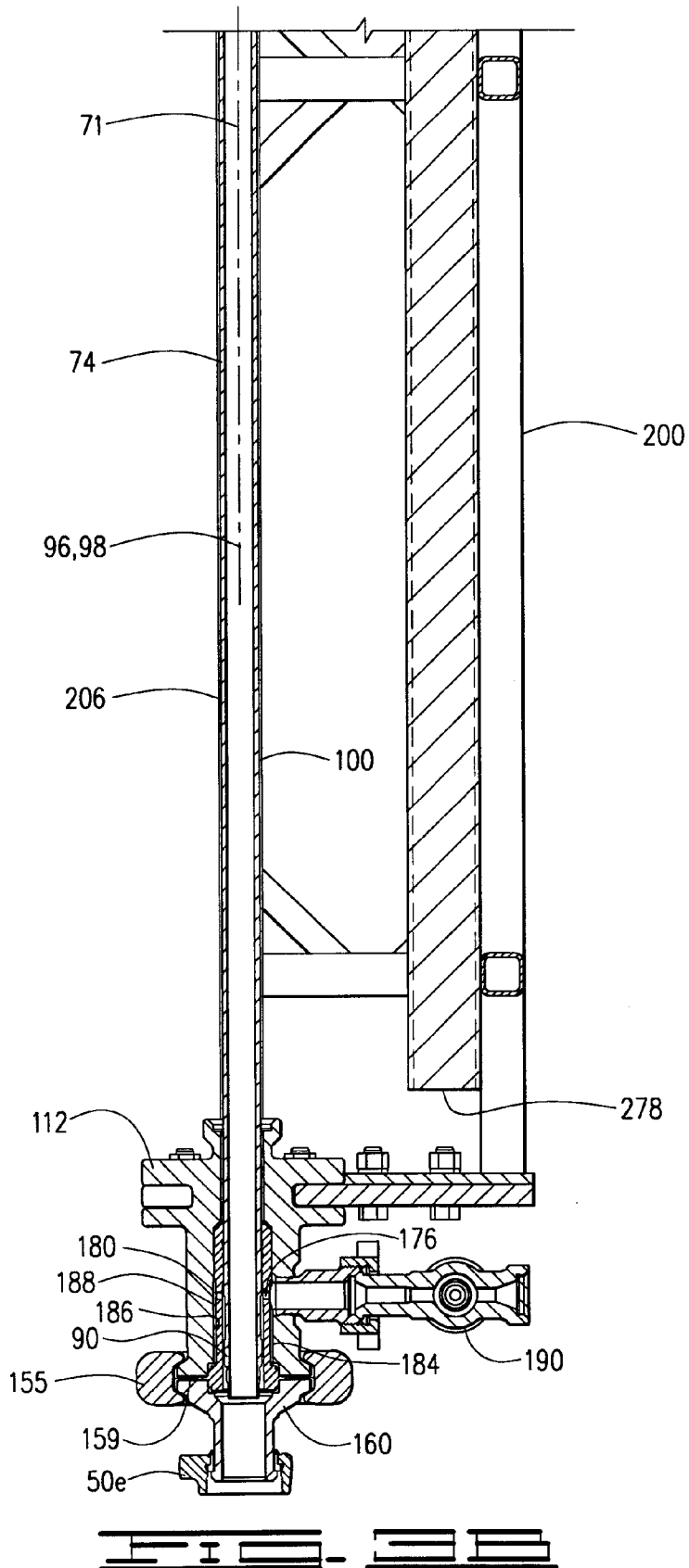
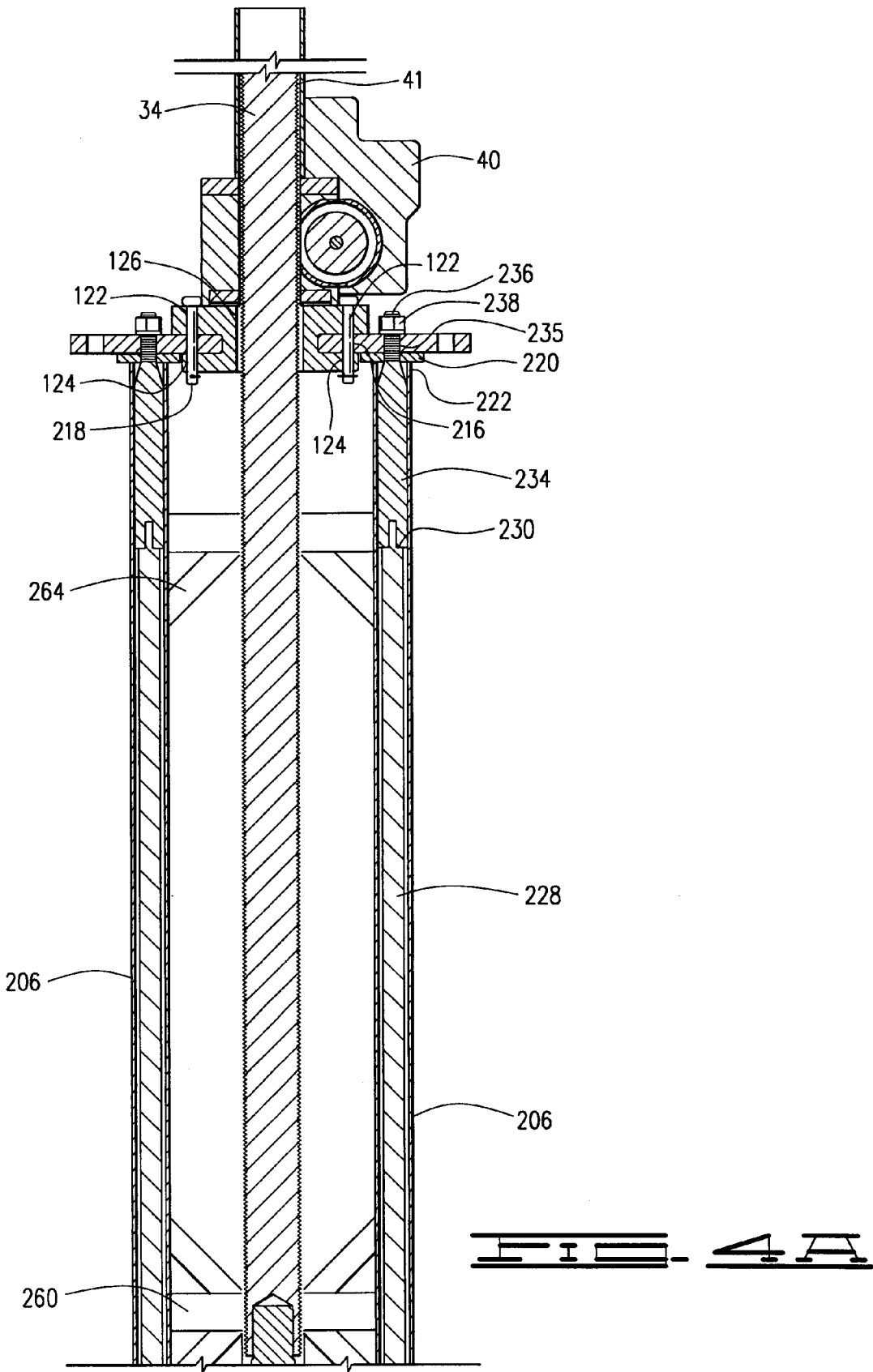
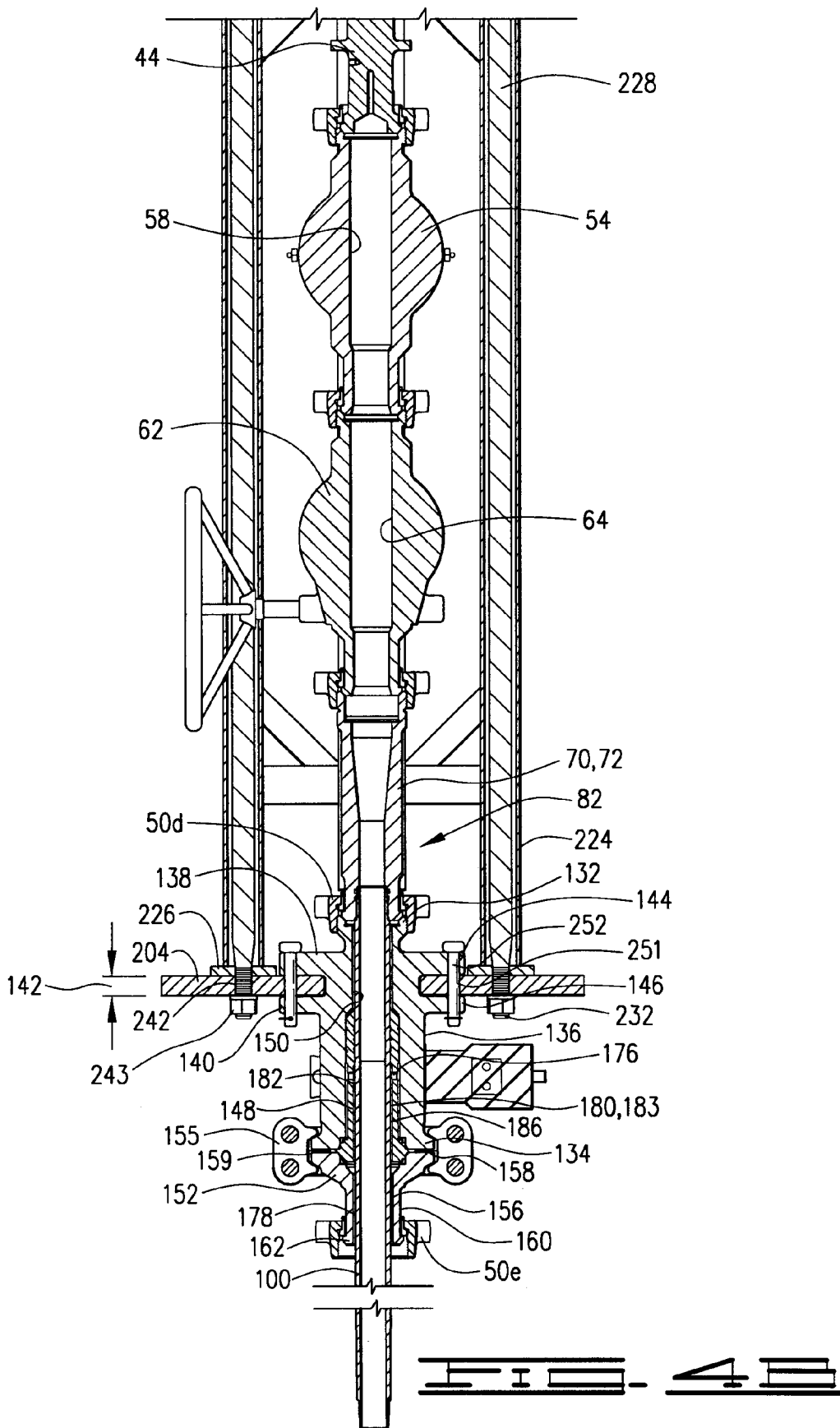
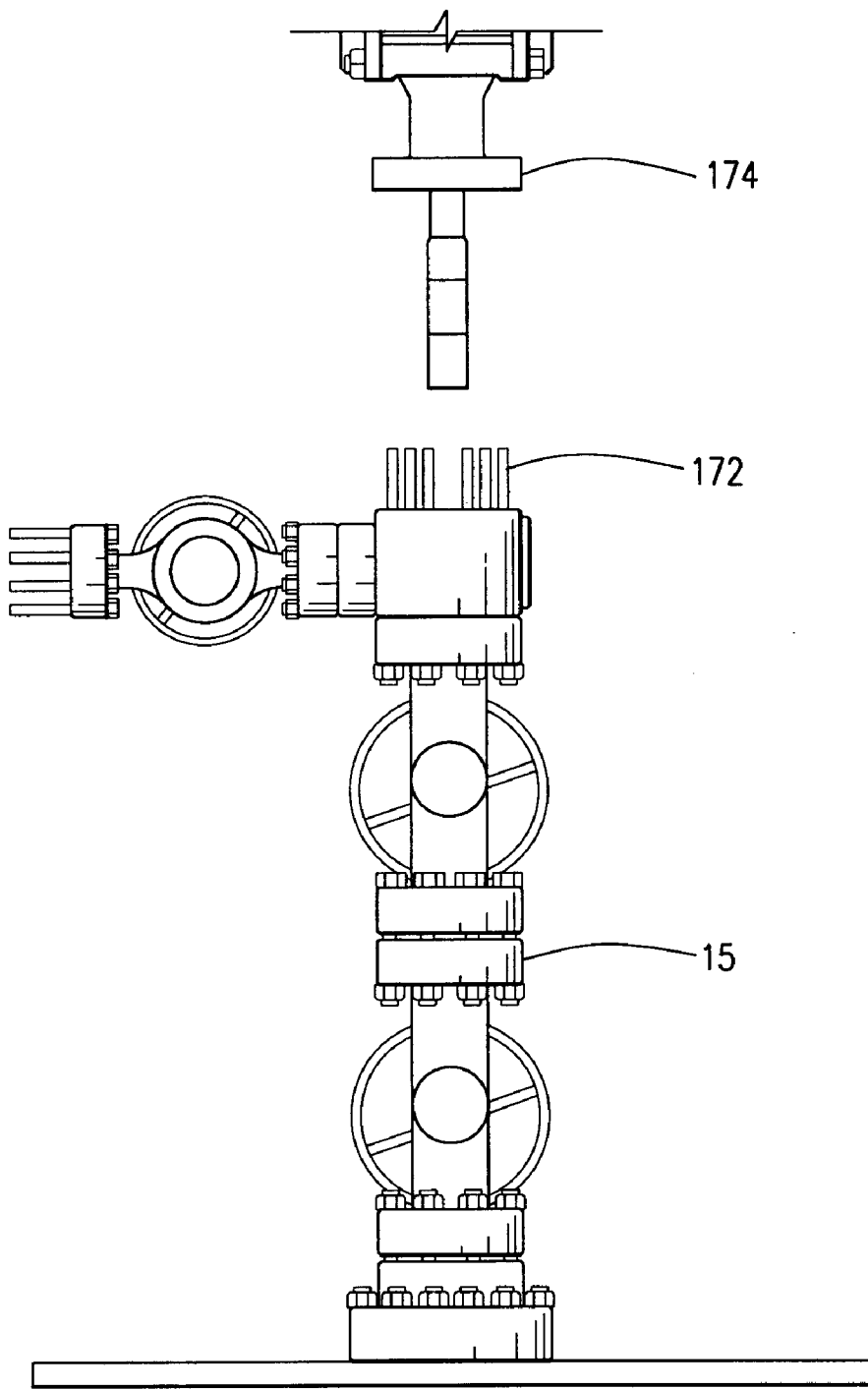

FIG. 3A









PRIOR ART

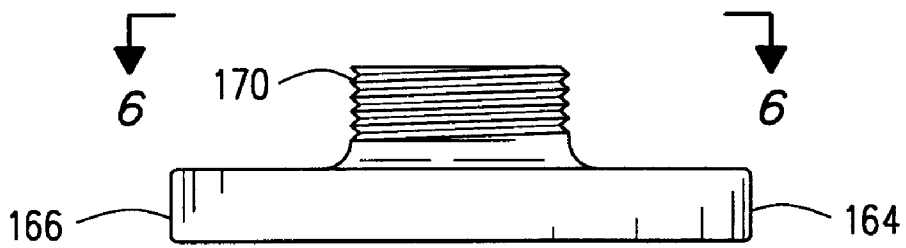
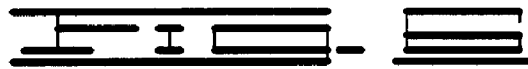
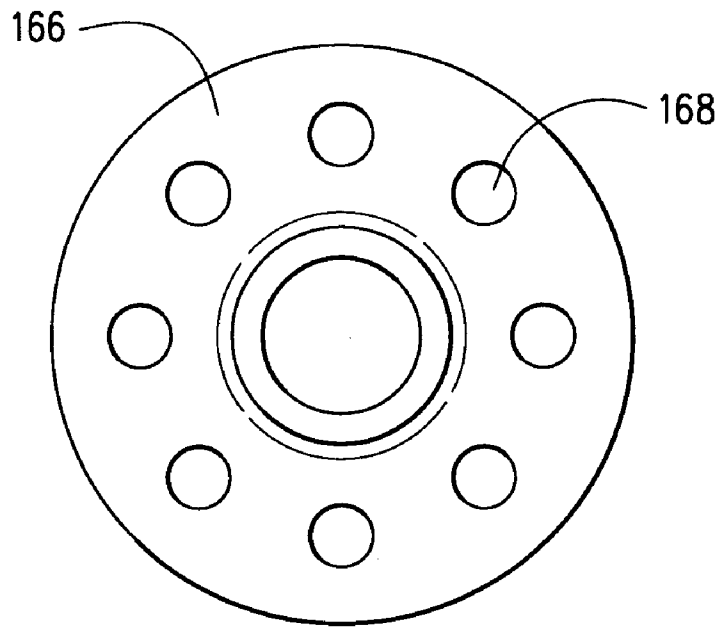

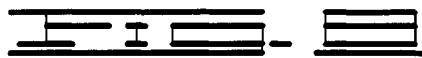
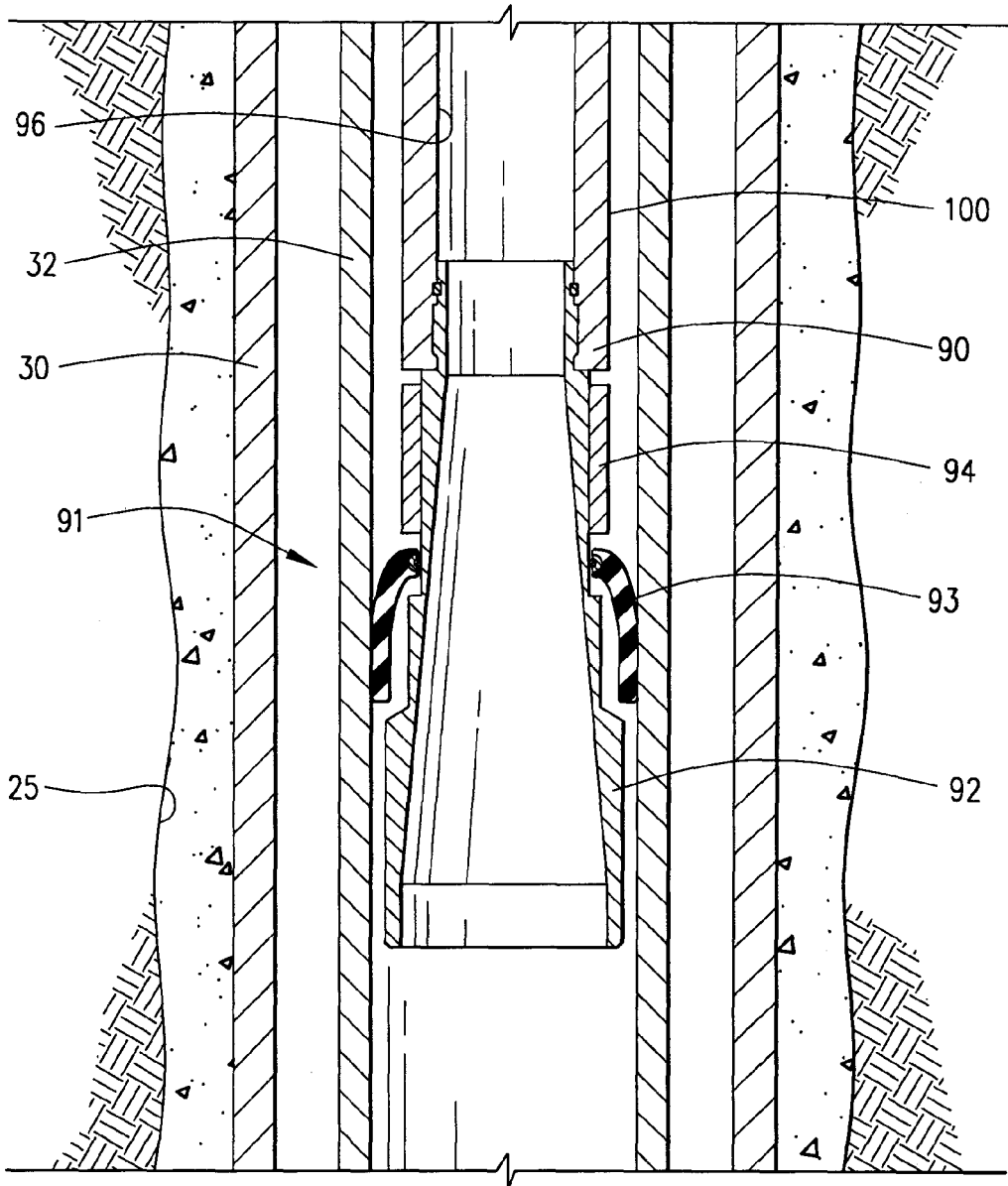

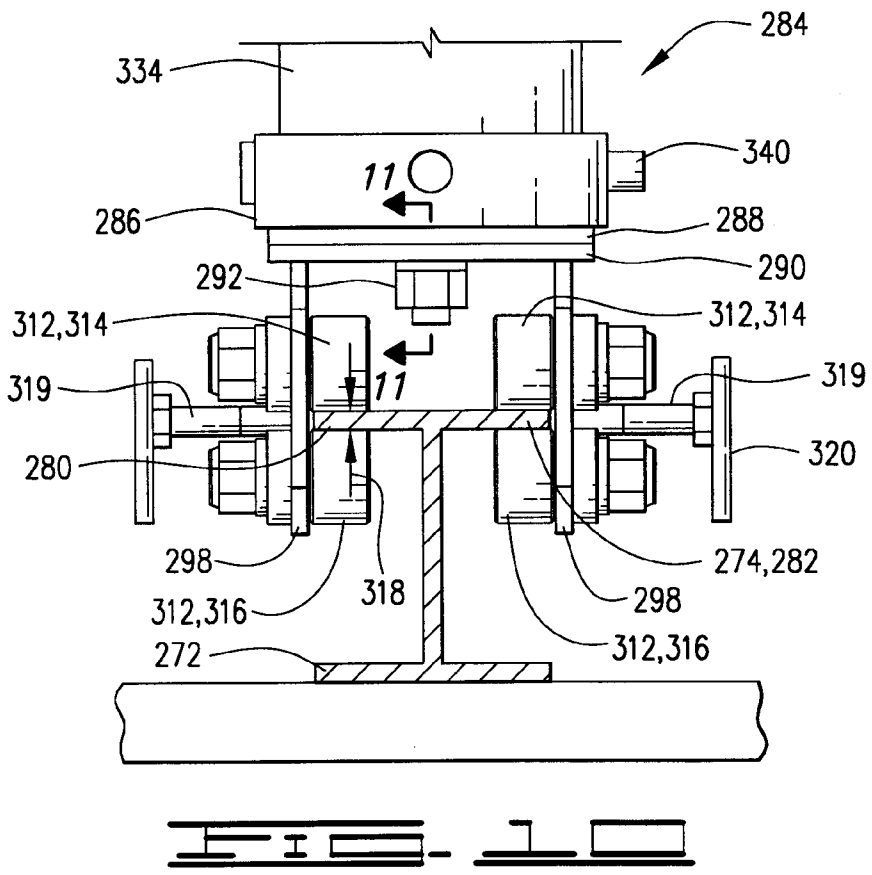
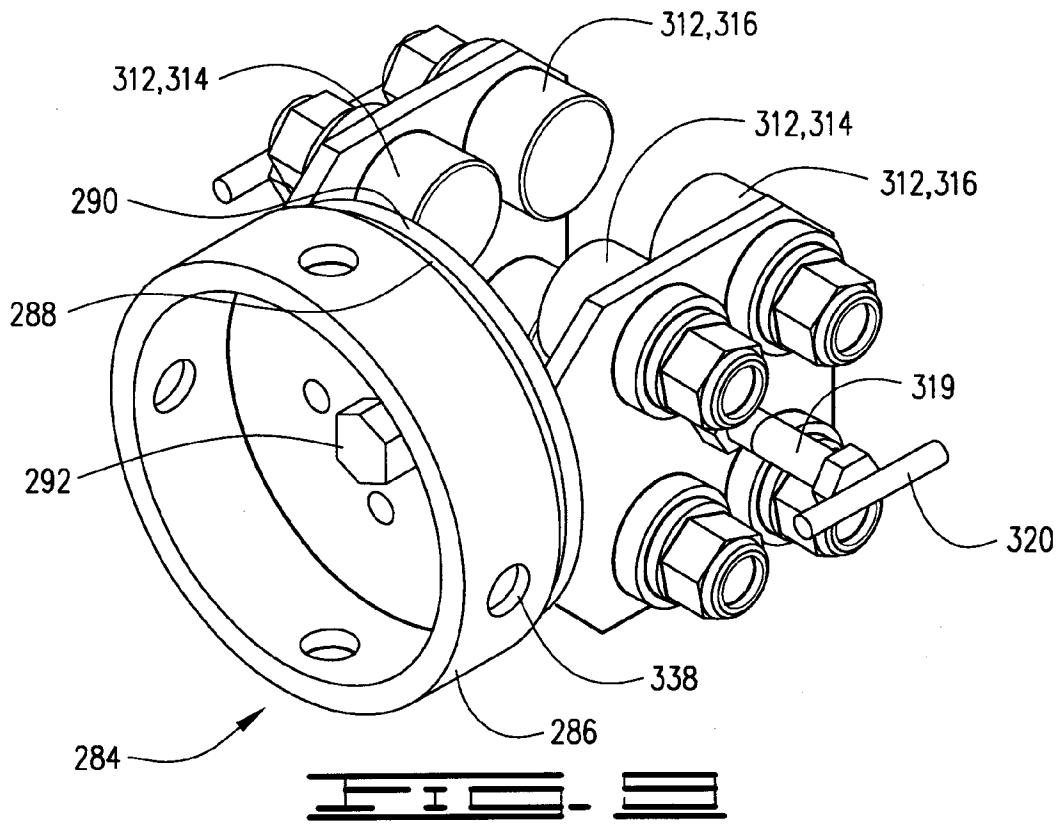

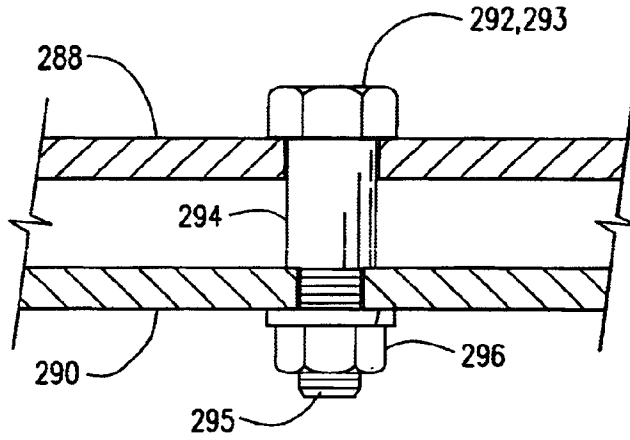

FIG. 11

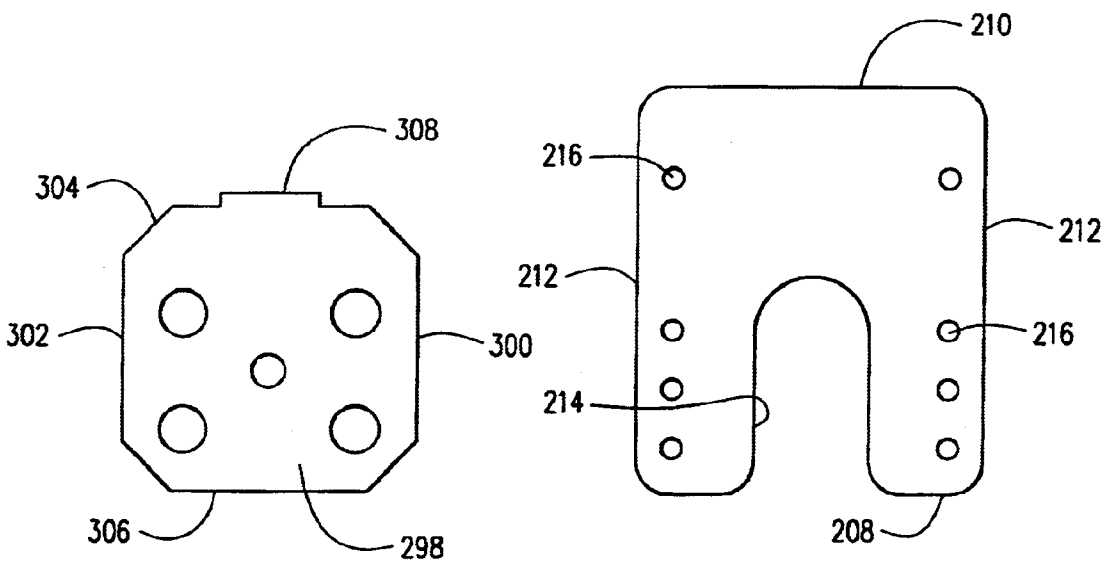
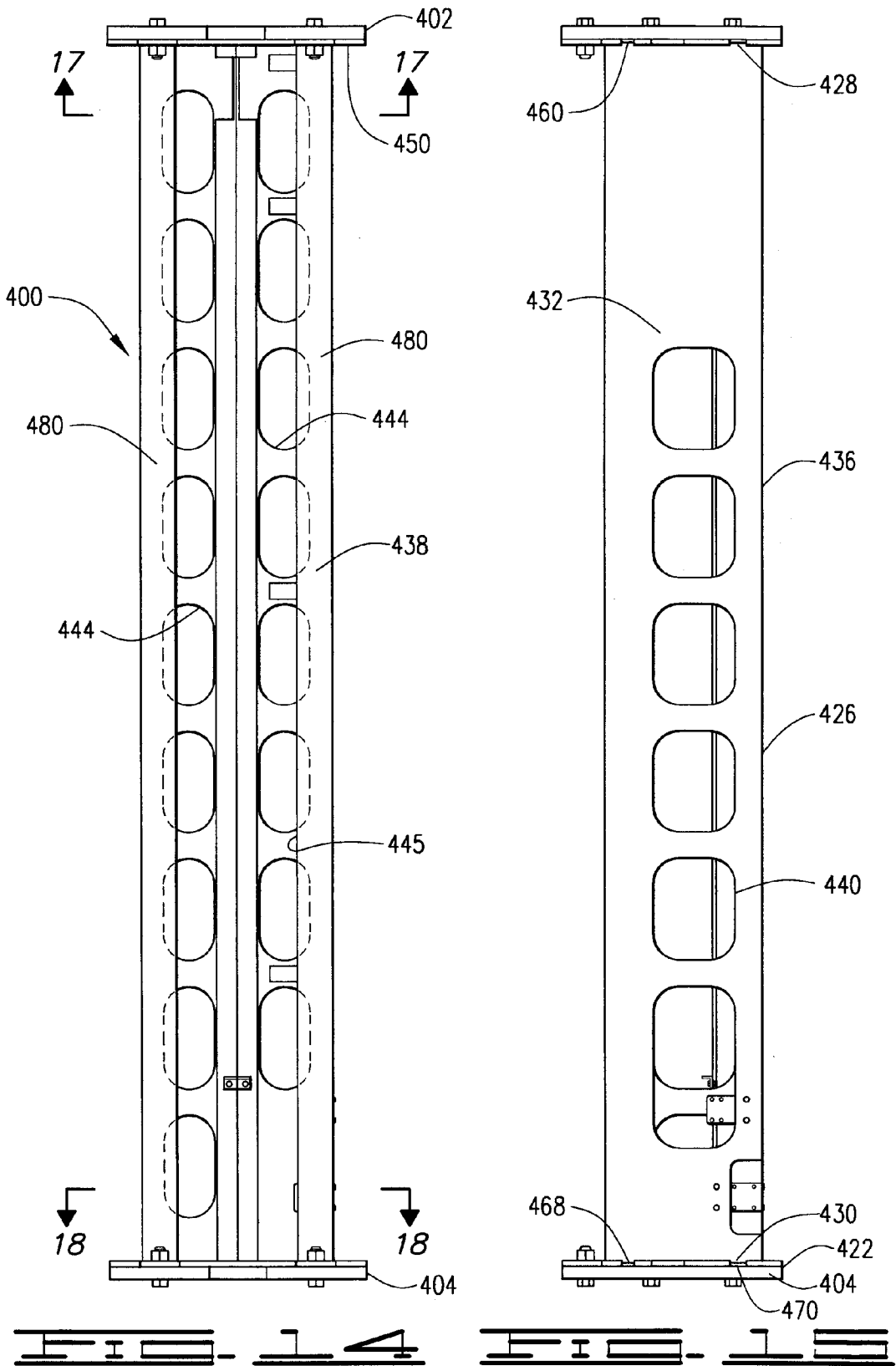
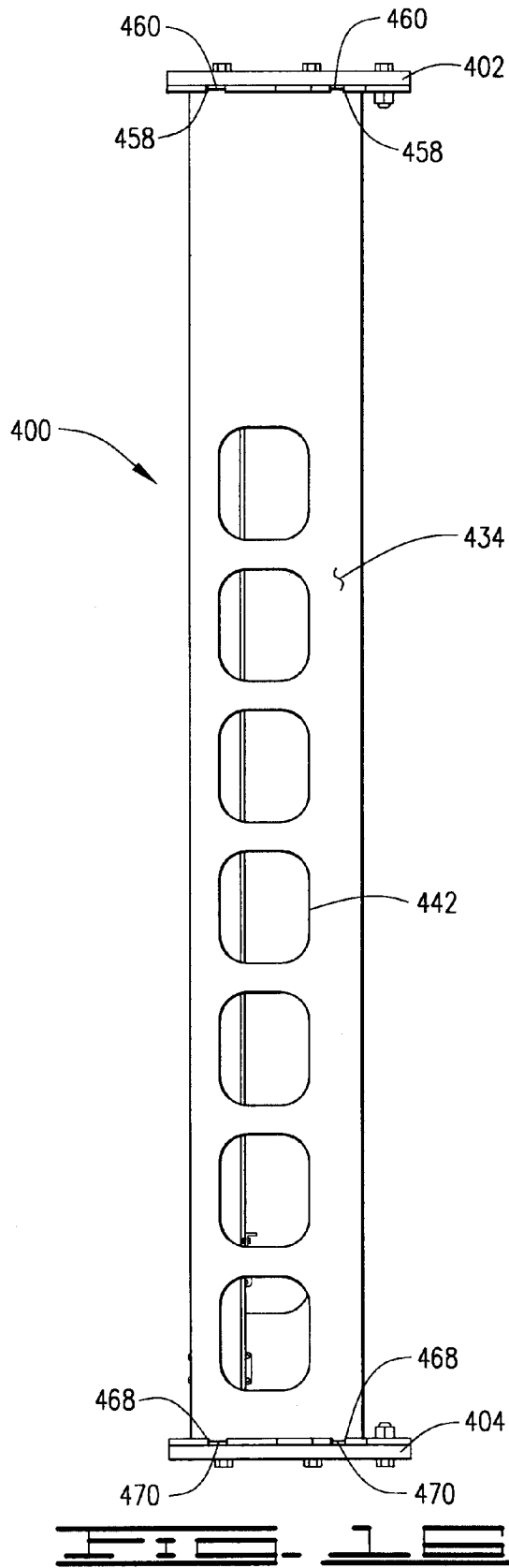
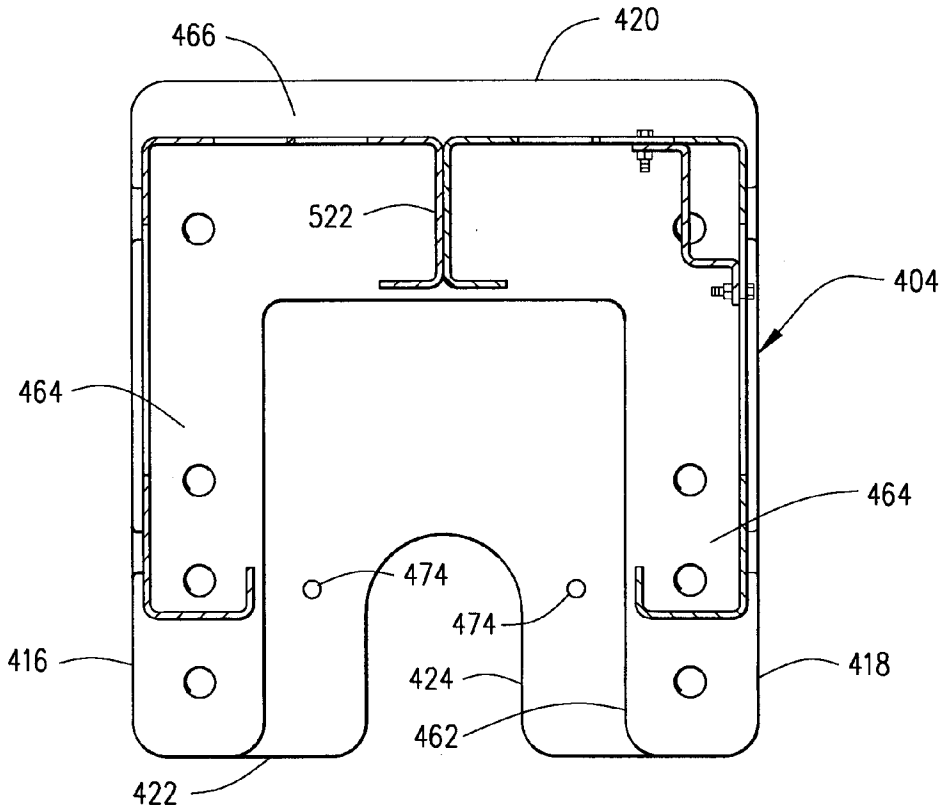
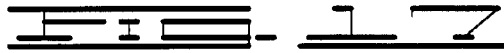
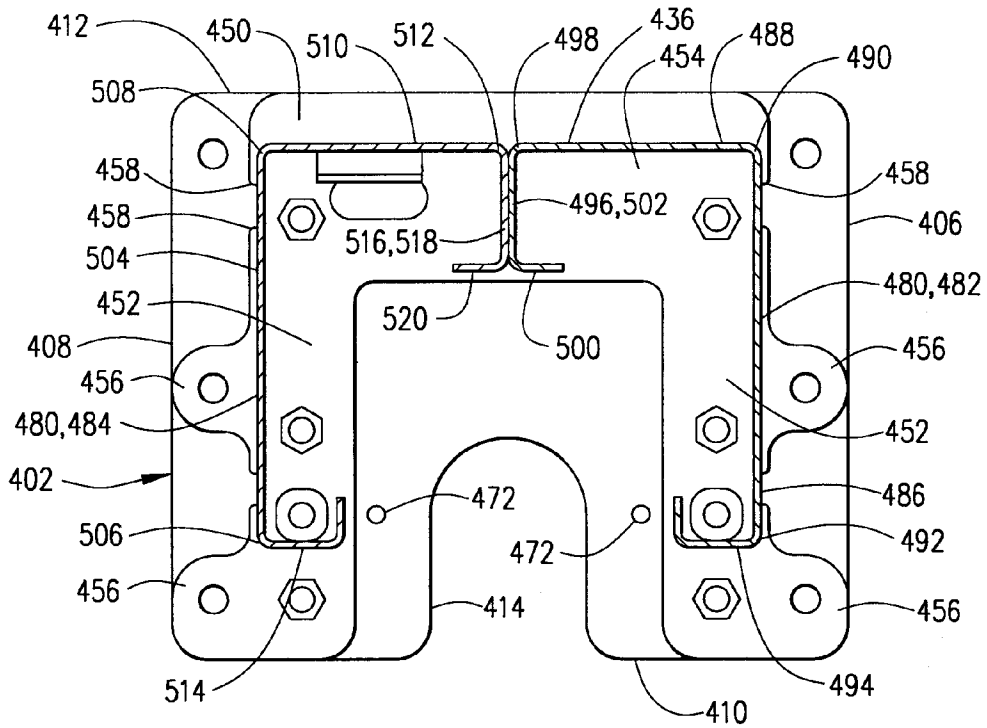

FIG. 12

FIG. 13







SCREW-DRIVEN WELLHEAD ISOLATION TOOL

BACKGROUND OF THE INVENTION

The present invention relates to wellhead equipment, and more particularly to a wellhead isolation tool for isolating a wellhead from the high pressures and the abrasive and/or caustic substances used in well treatment procedures.

It is not unusual for oil and gas wells to require stimulation to restart, or to improve, a flow of hydrocarbons from a hydrocarbon bearing formation. Such stimulation typically involves pumping fluid mixtures into the formation at high pressures. Such fluid mixtures often comprise acidic solutions and/or proppants that can be caustic and/or abrasive. Hydraulic fracturing, one common form of stimulating a hydrocarbon bearing formation, forces liquids and/or gasses which may include proppants or other abrasives therein into the formation. Extremely high pressures and high flow rates must be employed in the hydraulic fracturing process so that the proppants will be forced into the hydrocarbon bearing formation.

Conventional wellheads, commonly called well trees, are not generally designed to withstand the pressures and/or the abrasive or caustic nature of the substances required to stimulate a formation. Generally, the wellhead is designed to withstand pressures of less than about 5,000 psi. The substances utilized to stimulate the formation will be pumped into the well at pressures greatly exceeding 5,000 psi and may be as much as 20,000 psi.

There are a number of existing wellhead isolation tools that provide for the reciprocation of a mandrel through the wellhead into the well so that the substance utilized to stimulate the well passes through the mandrel and into the well without damaging the wellhead. However, because of the potentially dangerous nature of the well stimulation operation, there is a continuing need to provide a wellhead isolation tool which can be easily connected to the wellhead and disconnected therefrom, which provides easy access for connection of lines to supply the treatment fluid, and which provides an efficient and safe method to stimulate the hydrocarbon bearing formation.

SUMMARY OF THE INVENTION

The present invention is directed to a wellhead isolation tool for injecting substances through a wellhead into a tubular element, such as a production tubing, in a well. The wellhead isolation tool includes a tubular mandrel adapted to be received through a longitudinal passage defined by the wellhead. The tubular mandrel defines a mandrel flow passage and has a nonthreaded outer surface.

The wellhead isolation tool further includes at least one high pressure valve connected to an upper end of the tubular mandrel. Treatment substances such as fracturing fluids containing proppants and other treatment fluids may be communicated through the high pressure valve into the mandrel flow passage when the at least one high pressure valve is in an open position. The tubular mandrel has an upper position in which the mandrel does not extend through the wellhead into the well and a lower position in which a lower end of the mandrel is sealingly received in the production tubing in the well. A threaded drive rod for reciprocating the tubular mandrel is vertically aligned with the tubular mandrel and is connected to the at least one valve.

The wellhead isolation tool further includes a drive mechanism for vertically displacing the threaded rod to urge

the tubular mandrel downward through the wellhead and into the tubular element in the well. Once the tubular mandrel is sealingly engaged in the well, treatment fluids can be flowed into the well at extremely high pressures through the tubular mandrel without damaging the wellhead. The wellhead isolation tool further includes a support structure which provides for the easy location and connection of the wellhead isolation tool to the wellhead.

BRIEF DESCRIPTION OF THE DRAWINGS

FIG. 1 is perspective view of the wellhead isolation tool of the present invention.

FIGS. 2A–2C show a front elevational view of the wellhead isolation tool of the present invention.

FIGS. 3A–3B show a cross section of the wellhead taken from line 3–3 of FIGS. 2A–2C.

FIGS. 4A–4B are cross sections of the wellhead isolation tool of FIGS. 2A–2C showing the mandrel in a down position. The section is taken through the front legs and the mandrel.

FIG. 5 shows a prior art connection between a wellhead isolation tool and the wellhead.

FIG. 6 is a top view of a wellhead adapter sub of the present invention.

FIG. 7 is a side view of the wellhead adapter sub of the present invention.

FIG. 8 shows the lower end of the mandrel of the present invention sealingly engaged in production tubing in the well.

FIG. 9 shows a perspective view of the roller assembly of the present invention.

FIG. 10 is a view from line 10–10 of FIG. 3A.

FIG. 11 shows a view from line 11–11 of FIG. 10.

FIG. 12 is a detail showing a roller plate of the present invention.

FIG. 13 is a detail showing a support plate of the present invention.

FIG. 14 is a front view of an alternative embodiment of a support structure of the present invention.

FIG. 15 is a left-side elevation view of the support structure of FIG. 14.

FIG. 16 is a right-side elevation view of the support structure of FIG. 14.

FIG. 17 is a view from line 17–17 of FIG. 14, rotated 180°.

FIG. 18 is a view from line 18–18 of FIG. 14.

DETAILED DESCRIPTION OF A PREFERRED EMBODIMENT

Referring now to the drawings and more particularly to FIGS. 1–3, a wellhead isolation tool designated by the number 10 is shown. Wellhead isolation tool 10 has a front 12 and a rear 14. FIG. 2C shows wellhead isolation tool 10 connected to a wellhead 15 defining a longitudinal passage 17, positioned over a well 20. Well 20 may comprise a wellbore 25 having a casing 30 cemented therein. Well 20 has a tubular element, which may be a production tubing 32 disposed therein.

Wellhead isolation tool 10 comprises a drive rod 34 which is preferably an externally threaded drive rod. Drive rod 34 preferably has a regular screw thread on the exterior thereof. Drive rod 34 has a longitudinal central axis 35, an upper end 36 and a lower end 38. As will be explained in more detail herein, drive rod 34 may be moved vertically by a type of

screw drive mechanism. For example, a machine screwjack **39** driven by a motor **40** of a type known in the art may be utilized. The details of each are not depicted, but are shown schematically in the figures. Motor **40** is not shown in FIG. **1**, but is schematically represented in FIG. **2**. Screwjack **39** may be, for example, a machine screwjack model 50 MSJ, available from Nook Industries, Inc. An outer protective tube **41** may be disposed about drive rod **34** above screwjack **39**. Drive rod **34** has internal threads **42** at the lower end **38** thereof. A coupling **44** is threadedly connected at its upper end **46** to drive rod **34** at internal threads **42**. Coupling **44** has a lower end **48** with a wing nut assembly **50a** disposed thereabout. Wing nut assembly **50a** is connected at a threaded connection **52** to a valve **54** which may be referred to as an upper valve **54**. Wing nut assembly **50a** is connected to upper valve **54** at the upper end **56** thereof. Drive rod **34** is thus connected to upper valve **54** with coupling **44** and wing nut assembly **50a**. As will be explained in more detail hereinbelow, wing nut assembly **50a** may be easily disconnected from upper valve **54** so that a fluid line may be connected thereto. Upper valve **54** is depicted as a remote control valve which is movable between open and closed positions. In the open position, fluid may be displaced through a passage **58**, and in the closed position no fluid is allowed to pass therethrough.

Upper valve **54** has a lower end **60**. A wing nut assembly **50b** is disposed about the lower end **60** of upper valve **54**, and connects upper valve **54** with a lower valve **62**. There are a plurality of wing nuts **50** utilized with the wellhead isolation tool **10**. Wing nuts **50** are referred to as wing nuts, or wing nut assemblies **50a-50e** for ease of identification. Wing nuts **50a-50e** may be identical to one another.

Lower valve **62** is depicted as a manually operated valve which defines a passage **64**. Lower valve **62** is movable between an open position wherein fluid may be displaced through passage **64** and a closed position wherein fluid flow therethrough is prevented. Although the wellhead isolation tool **10** of the present invention shows two valves, namely upper and lower valves **54** and **62**, respectively, it is understood that wellhead isolation tool **10** will have at least one valve and preferably a plurality of valves. In the embodiment shown, a remote control valve is shown as upper valve **54** and a manually operated valve is shown for lower valve **62**. The positions of the valves may be switched or both may be manual or remote control.

Lower valve **62** is connected at its upper end **66** to upper valve **54** with wing nut **50b**, and is connected at its lower end **68** with a wing nut **50c** to a mandrel assembly **70**. Mandrel assembly **70** has a longitudinal central axis **71** and comprises an upper mandrel **72** and a lower mandrel **74**. Longitudinal central axis **71** and longitudinal central axis **35** are collinear, such that drive rod **34** and mandrel assembly **70** have a common longitudinal axis and are thus coaxial. Upper mandrel **72** is connected at its upper end **76** to wing nut **50c** at the lower end **68** of lower valve **62**. A wing nut **50d** is disposed about lower end **78** of upper mandrel **72**. Mandrel assembly **70** may be reciprocated between an upper position **80** as shown in FIGS. **2A-2C**, to a lower position **82** as shown in FIGS. **4A-4B**. In upper position **80**, wing nut **50d** disposed about the lower end of **78** of upper mandrel **72** is not connected to any other part. In lower position **82**, however, wing nut **50d** is connected to a lower central support, as will be explained in more detail hereinbelow.

Lower mandrel **74** has an upper end **84** connected to upper mandrel **72** at threaded connection **86**. An O-ring seal **88** may be disposed above threaded connection **86** to provide a sealed connection between the upper and lower mandrels **72**

and **74**. Lower mandrel **74** has a lower end **90**. Lower end **90** is connected to a sealing device **91** as shown in FIG. **8**. Sealing device **91** may comprise a cup mandrel **92** with a cup seal **93** connected thereto. A shoe **94** is disposed about cup mandrel **92**. A diffuser, like that shown in U.S. Pat. No. 4,262,743, the details of which are incorporated herein by reference, may also be used. Mandrel assembly **70** defines a passageway **96** for the flow of substances such as treating fluids or other fluids therethrough. Passages **58**, **64** and passageway **96** thus define a longitudinal central flow passage **98** which provides for flow therethrough into production tubing **32**. Lower mandrel **74** has an outer surface **100**.

Wellhead isolation tool **10** further includes upper and lower central supports **110** and **112** respectively, which may also be referred to as upper and lower hubs **110** and **112**. Upper central support **110** comprises a body portion **114** and upper and lower flanges **116** and **118**, respectively, extending outwardly from body portion **114**. Upper and lower flanges **116** and **118** define a space **120** therebetween. Upper and lower flanges **116** and **118** are preferably circular flanges. Screwjack **39** and motor **40**, or other means for vertically displacing drive rod **34**, may be mounted by any means known in the art to upper flange **116**. Upper and lower flanges **116** and **118** define pin receiving holes **122** and **124**, respectively. Pin receiving holes **122** and **124** are aligned with one another. Upper central support **110** defines an opening **126** therethrough which allows drive rod **34** to reciprocate between its upper and lower positions **80** and **82**, respectively.

Wellhead isolation tool **10** also comprises lower central support **112**. Lower central support **112** has an upper end **132** and a lower end **134**. Upper end **132** preferably has a threaded outer surface so that in the lower position **82** of mandrel assembly **70**, wing nut **50d** may be threadedly connected thereto to connect upper mandrel **72** to lower central support **112**, and fix mandrel assembly **70** in lower position **82**. Lower central support **112** includes a body portion **136** and has upper and lower flanges **138** and **140** extending radially outwardly therefrom. Upper and lower flanges **138** and **140** define a space **142** therebetween. Upper flange **138** has a plurality of pin receiving holes **144** defined therethrough and lower flange **140** has a plurality of pin receiving holes **146** defined therethrough. Pin receiving holes **144** and **146** are aligned with one another. Lower central support **112** includes a sleeve **148**. Lower central support **112** defines a central opening **150** to allow lower mandrel **74** to pass therethrough and be moved vertically in and out of wellhead **15**. A wellhead adapter **152** is connected to lower central support **112** at its lower end **134**. Wellhead adapter **152** is connected to lower central support **112** with a clamp **154** which may comprise two clamp portions **155** bolted together, or which may comprise any type of clamp known in the art.

Sleeve **148** extends downwardly into a central opening **156** defined by wellhead adapter **152**. Sleeve **148** has a flange **158** positioned between lower central support **112** and wellhead adapter **152**. A gap **159** thus exists between wellhead adapter **152** and lower central support **112**. Sleeve **148** is held in place in lower central support **112** by wellhead adapter **152** which is connected to lower central support **112** with clamp **154**. Sleeve **148** is a removable sleeve such that sleeves having any desired inner diameter may be utilized to accommodate mandrels of different outer diameters. Wellhead adapter **152** comprises a wellhead adapter housing **160** having a wing nut **50e** connected to a lower end **162** thereof.

Wellhead isolation tool **10** may further comprise a wellhead adapter sub **164** as shown in FIGS. **6** and **7**. Wellhead

adapter sub **164**, which may be also referred to as mounting sub **164**, comprises a mounting plate **166** having a plurality of bolt or pin holes **168** therethrough. A threaded neck **170** extends upwardly from mounting plate **166**. A prior art wellhead **15** is depicted in FIG. **5** and, as shown therein has a plurality of bolts **172** extending upwardly therefrom in a defined bolt pattern. Bolt holes **168** in wellhead adapter sub **164** are adapted to match the pattern of bolts **172** so that wellhead adapter sub **164** may be mounted to wellhead **15** simply by placing wellhead adapter sub **164** thereon and threading nuts onto the bolts **172** extending upwardly on wellhead **15**. As shown in FIG. **2C**, wing nut **50e** may be connected to wellhead adapter sub **164** simply by threading wing nut **50e** thereon, thus connecting wellhead adapter **152** to wellhead **15**. Prior art wellhead isolation tools included a wellhead adapter **174** that had mating holes to connect directly to the bolts **172** as shown in FIG. **5**.

The wellhead isolation tool **10** of the present invention provides for easier connection and disconnection of the wellhead isolation tool **10** on any wellhead **15**, including those with differing bolt patterns, since a plurality of wellhead adapter subs **164** may be designed having different bolt patterns to match the bolt patterns on different wellheads. The wellhead adapter sub **164** can be placed on the wellhead **15** prior to the time the wellhead isolation tool **10** is to be connected thereto which will provide for easier connections that can be made in less time, since the wellhead adapter **152** can simply be threaded to wellhead adapter sub **164**.

Sleeve **148** has openings **176** therethrough. An annulus **178** is defined between outer surface **100** of lower mandrel **74** and wellhead adapter **152**. Likewise, an annulus **180** exists between the outer surface **100** of lower mandrel **74** and an inner diameter **182** defined by sleeve **148**. Inner diameter **182** defines a portion of central opening **150** in lower central support **112**. Annulus **178** and annulus **180** define a fluid path **183** that is communicated with an annulus **184** through openings **176**. Annulus **184** is defined between an outer diameter **186** of sleeve **148** and inner diameter **188** of body portion **136** of lower central support **112**. When lower mandrel **74** is inserted through wellhead **15** into well **20**, fluid can pass from a relief valve **190**, through openings **176**, annulus **178** and annulus **180** to urge cup seal **93** inwardly so that it will not engage production tubing **32** as it is lowered therethrough. Once the wellhead isolation tool **10** reaches its desired location, fluid flow through relief valve **190** ceases, and in operation, the cup seal **93** will expand to engage production tubing **32** as shown in FIG. **8**. Although in the embodiment shown, the sealing device **91** engages production tubing **32**, the mandrel assembly **70** and sealing device **91** can be used to seal other tubular elements, such as casing **30** in the well **20**.

Wellhead isolation tool **10** includes a support structure **200**. Support structure **200** includes an upper support plate **202**, a lower support plate **204** and a plurality of vertical support members, such as support legs **206**. In the embodiment shown, support structure **200** includes four support legs **206**.

Upper support plate **202** has forward and rear edges **208** and **210** respectively and side edges **212**. Upper support plate **202** has a cutout **214** which may be referred to as a semicircular or generally U-shaped cutout **214** on the forward edge **208** thereof. The U-shaped cutout **214** is adapted to be received in space **120** about body portion **114** of upper central support **110**. Upper support plate **202** has a plurality of openings **216** defined therethrough. Openings **216** are positioned to align with pin receiving holes **122** and **124** so that connectors, such as pins **218**, may be inserted there-

through to mount upper central support **110** to upper support plate **202**. One or more pins **218** may be utilized. Support legs **206** are connected to upper support strips **220**, preferably by welding or other means known in the art, at upper end **222** thereof. Support legs **206** likewise have a lower end **224**. Support legs **206** are connected by welding or other means known in the art at lower end **224** to lower support strips **226**, which may be identical to upper support strips **220**. Support legs **206** have tension rods **228** disposed therein. In the embodiment shown, each of four support legs **206** has a tension rod **228** therein. If desired, tension rods **228** may be included only in the two support legs **206** at the front **12** of wellhead isolation tool **10**. Tension rods **228** have an upper end **230** and a lower end **232**. Upper end **230** is threadedly connected to a tension rod connector **234** which extends upwardly in support legs **206** through upper support strips **220** and openings **235** defined in upper support plate **202**. Tension rod connectors **234** have an upper end **236** which is threaded so that nuts **238** may be threaded thereon thus connecting support legs **206** and tension rods **228** to upper support plate **202**. A nut and bolt arrangement **239** may be utilized to further connect upper support strips **220** to upper support plate **202**.

Lower end **232** of tension rod **228** is threaded. Tension rods **228** extend through openings defined in lower support strips **226** and through openings **242** defined in lower support plate **204**. Nuts **243** are threaded on lower ends **232** of tension rods **228** to connect tension rods **228** and thus support legs **206** to lower support plate **204**.

Lower support plate **204** has a forward edge **244**, a rear edge **246** and side edges **248**. Forward edge **244** has a semicircular or generally U-shaped cutout **250** so that lower support plate **204** may be received in space **142** between the upper and lower flanges **138** and **140** of lower central support **112**. Upper and lower support plates **202** and **204** may be identical and thus interchangeable. Lower support plate **204** has a plurality of openings **251** positioned to align with pin receiving holes **144** in upper flange **138** and pin receiving holes **146** in lower flange **140** so that pins **252** may be inserted therethrough to mount lower support plate **204** to lower central support **112**. One or more pins **252** may be utilized and may be held in place with a cotter pin or by other means known in the art.

Support structure **200** has a forward, or front **253**, and a back or rear **254**, corresponding to the front and rear **12** and **14** of wellhead isolation tool **10**, and has sides **256**. Support structure **200** further includes a plurality of rear cross braces **260**. The embodiment shown includes three rear cross braces **260** that extend between two support legs **206** at the rear **254** of support structure **200**. Rear cross braces **260** may be connected by welding or by other means known in the art.

Wellhead isolation tool **10** may also include side cross braces **262** at the sides **256** of the well isolation tool **10**. Side cross braces **262** may be connected by welding or otherwise and extend from the support legs **206** at the front **253** of support structure **200** to the support legs **206** at the rear **254** of support structure **200**. Support structure **200** may also include rear angle braces and side angle braces **264** and **266**, respectively, at locations where rear and side cross braces **260** and **262** are mounted. Rear and side angle braces **264** and **266** may be welded or otherwise connected to support legs **206** and to the rear and side cross braces **260** and **262** respectively.

Support structure **200** likewise includes a guide beam **268**. Guide beam **268** essentially comprises an I-beam having a center section **270**, rear flanges **272** and forward

flanges 274 extending from center section 270. Guide beam 268 is mounted to rear cross braces 260 by welding or other means known in the art. Guide beam 268 has an upper end 276 and a lower end 278. Guide beam 268 has a pair of forward flanges 274 which may be referred to as first and second forward flanges 280 and 282 respectively.

Wellhead isolation tool 10 further includes a roller assembly 284. A perspective view of roller assembly 284 is shown in FIG. 9. Roller assembly 284 includes a base 286 which is preferably a circular base, having a cap 288 rigidly connected thereto by welding or other means known in the art as shown in FIG. 10. Roller assembly 284 also includes a mounting plate 290, which is rotatably mounted to cap 288, with a nut and bolt arrangement 292, and can be rotatably mounted thereto by any means known in the art. For example a hexagon socket head shouldered screw may be utilized to provide the necessary rotation. FIG. 11 shows a bolt 293 with a shoulder 294 extending through cap 288. Threads 295, which are smaller than shoulder 294, extend through mounting plate 290, and a nut 296 is threaded thereon. Such an arrangement will allow rotation of cap 288 and base 286, relative to mounting plate 290. Roller assembly 284 includes a pair of roller plates 298, a detail of which is shown in FIG. 12. Roller plates 298 have first and second sides 300 and 302 and front and rear edges 304 and 306. A tang 308 extends from front edge 304 and may be received in corresponding slots (not shown) defined in mounting plate 290, so that roller plates 298 may be welded or otherwise affixed to mounting plate 290.

A plurality of rollers, and in the embodiment shown four rollers 312 are mounted to each roller plate 298. Rollers 312 may be of any type known in the art, such as for example a cam follower with bearings, and are mounted by any manner known in the art. Each roller plate 298 has a pair of forward rollers 314 and rear rollers 316. A space 318 is defined between front and rear rollers 314 and 316, respectively. First and second forward flanges 280 and 282 of guide beam 268 are received between forward and rear rollers 314 and 316. A bolt 319 with an arm 320 is likewise attached to each roller plate 298. Bolt 319 can be threaded through roller plates 298.

Roller assembly 284 may be connected to one of upper or lower valves 54 or 62 and in the embodiment shown is connected to both of upper and lower valves 54 and 62. An adjustable nut 330 of a type known in the art may be threaded into a threaded cavity 332 in the rear side of upper valve 54 and lower valve 62. Adjustable nut 330 has a head portion 334 that extends from cavity 332. Head portion 334 has openings 336 defined therethrough. Openings 336 are aligned with openings 338 in base 286 of roller assembly 284. Pins 340 may be inserted through openings 336 and 338 to connect upper and lower valves 54 and 62 to roller assembly 284.

Roller assembly 284 will initially be positioned so that first and second forward flanges 280 and 282 on guide beam 268 are positioned between the forward and rear rollers 314 and 316, respectively. Base 286 can be rotated so that openings 338 will align with openings 336 to allow pins 340 to be inserted therethrough.

The operation of the well isolation tool may be described as follows. Well isolation tool 10 is first positioned over a wellhead 15. A wellhead adapter sub 164 is connected to the upper end of wellhead 15. Wellhead isolation tool 10 is lowered with the mandrel assembly 70 in its upper position 80, so that wing nut 50e may be threaded onto wellhead adapter sub 164. Prior to the time wellhead isolation tool 10

is connected to wellhead 15, valves 342 and 344 on wellhead 15 are closed. Likewise, upper and lower valves 54 and 62 on wellhead isolation tool 10 are closed to prevent flow therethrough. Once the wellhead isolation tool 10 is connected to wellhead 15, valves 342 and 344 are opened. Motor 40 can then be actuated to urge drive rod 34 downwardly which in turn moves mandrel assembly 70 downwardly. Lower mandrel 74 is thus moved downwardly through longitudinal passage 17 in wellhead 15 and into well 20. More specifically, sealing device 91 connected to lower mandrel 74 is sealingly received in a tubular element in well 20, which is preferably production tubing 32, but which may be a casing.

Once sealing device 91 sealingly engages production tubing 32, wing nut 50d is connected to upper end 132 of lower central support 112, and support structure 200 can be removed. All that is required is to simply disconnect wing nut 50a from upper valve 54 and to remove pins 252 and pins 340. Prior to removing pins 340, bolts 319 can be rotated to engage first and second forward flanges 280 and 282 to hold roller assemblies 284 in place on guide beam 268 when the support structure 200 is removed. Lower support plate 204 can then simply be removed from between upper and lower flanges 138 and 140 on lower central support 112 and the support structure 200 can be moved as a unit.

A flow line of a type known in the art (not shown) can then be connected to upper valve 54. Upper valve 54 and lower valve 62 can be opened to allow fluids or other substances to be flowed therethrough at high pressures through lower mandrel 74 into production tubing 32 and into a hydrocarbon containing formation therebelow. When the fracturing or other treatment is complete, wellhead isolation tool 10 provides for easy removal. Upper and lower valves 54 and 62 are closed after the treatment is complete. The fluid line is then disconnected from upper valve 54 and the support structure 200 is reconnected simply by positioning lower support plate 204 in space 142 and reconnecting wing nut 50a to upper valve 54. Pins 252 are reinserted, as are pins 340 in roller assembly 284, and wing nut 50d is disconnected from lower central support 112. Motor 40 can then be actuated to cause drive rod 34 to move upwardly which will, because the wing nut 50a has been reconnected to upper valve 54, cause mandrel assembly 70 to be lifted upwardly until the lower end 90 of lower mandrel 74 and sealing device 91 are moved above valves 342 and 344. Valves 342 and 344 are closed after lower mandrel 74 is removed therefrom. Once valves 342 and 344 are closed, the mandrel assembly can be moved to its upper position 80. Wellhead isolation tool 10 can be removed simply by disconnecting wing nut 50e and moving wellhead isolation tool 10 as a unit away from wellhead 15.

In the embodiment shown in FIGS. 1-13, wellhead isolation tool 10 includes a support structure 200. An alternative embodiment of a support structure generally designated by the numeral 400 is shown in FIGS. 14-18. Support structure 400 includes upper support plate 402 and lower support plate 404. The upper and lower support plates 402 and 404, respectively, may be identical to upper and lower support plates 202 and 204, respectively. Upper plate 402, therefore, has left and right sides, or edges 406 and 408 and front and rear edges 410 and 412. Front edge 410 defines a generally U-shaped or semicircular cutout 414. Lower support plate 404 has a left edge 416, a right edge 418 and a rear edge 420. Lower support plate 404 has a front edge 422 defining a generally U-shaped or semicircular cutout 424.

A vertical support member or support frame 426 has an upper end 428 and a lower end 430. Support frame 426 has

a left side **432**, a right side **434**, a rear side or rear panel **436**, and a front **438**. Left side **432** has a plurality of access openings **440** defined therein. Likewise, right side **434** has a plurality of access openings **442** defined therein. Access openings **440** and **442** may be of any configuration and may be arranged in any desired patterns so as to allow access to wing nut assemblies **50**, upper and lower valves **54** and **62**, mandrel assembly **70** and any other parts of the wellhead isolation tool **10** to which access is desired. Rear side **436** may also have a plurality of access openings **444** defined therein. Front **438** of support frame **426** preferably defines an opening **445** extending from the upper end **428** to the lower end **430** thereof, which will also provide access to upper and lower valves **54** and **62** and other parts of the wellhead isolation tool **10**. Thus, a cross section of support frame **426** defines a generally rectangular periphery.

Support structure **400** may include an upper mounting plate **450**. Upper mounting plate **450** may include side mounting strips **452** connected by a rear mounting strip **454**. Upper mounting plate **450** may further include ears **456** extending from side mounting strips **452**. Upper mounting plate **450** is connected to upper support plate **402** with bolts or other connectors known in the art. Screwjack **39** and motor **40**, or other mechanism to move drive rod **34** may be mounted to upper support plate **402**.

Upper mounting plate **450** may have notches **458** for receiving tangs **460** at the upper end of support frame **426**. Support frame **426** is preferably welded at the upper end **428** thereof to upper mounting plate **450**.

Support structure **400** may also include a lower mounting plate **462** which includes side mounting strips **464** and a rear mounting strip **466** extending between and connecting side mounting strips **464**. Lower mounting plate **462** may be connected to lower support plate **404** with bolts or other connectors known in the art.

Lower mounting plate **462** may have notches or grooves **468** defined therein for receiving tangs **470** defined at the lower end **430** of support frame **426**. Upper support plate **402** has a pair of openings **472** positioned identically to openings **124** in upper support plate **202**. Lower support plate **404** has a pair of openings **474** positioned identically to openings **251** in lower support plate **204**. Thus, support structure **400** maybe pinned to upper hub **110** and lower hub **112** in the same manner as support structure **200**. In other words, pins **218** may be inserted through openings **472** and pin receiving holes **122** and **124**. Likewise, pins **252** may be inserted through openings **474** and pin receiving holes **144** and **146**.

Support frame **426** may comprise support frame portions or support frame halves **480**. Support frame portions **480** may be referred to as first and second or left and right frame portions **482** and **484**, respectively, for ease of identification. As is apparent from the drawings, first and second frame portions **482** and **484** have identical cross sections but may have access openings of different sizes and in different locations.

Left frame portion **482** may comprise a side panel **486** and a rear panel **488**. Side panel **486** has a rear end **490** and a forward end **492**. An L-shaped flange **494** extends inwardly from forward end **492**. Likewise, an L-shaped flange **496** extends inwardly from an inner edge **498**. L-shaped flange **496** comprises a foot portion **500** and a leg portion **502**.

Right frame portion **484** comprises a side panel **504** having a forward end **506** and a rear end **508**. A rear panel **510** extends from the rear end **508** of side panel **504**. Rear panel **510** has an inner end **512**. An L-shaped flange **514** is

connected to and extends inwardly from forward end **506** of side panel **504**. An L-shaped flange **516** is connected to and extends inwardly from inner end **512** of rear panel **510**. L-shaped flange **516** has a leg portion **518** and a foot portion **520**.

Bolts may be utilized to connect the first and second frame portions **482** and **484** through leg portions **502** and **518** of L-shaped flanges **496** and **516**, respectively. As is apparent from the drawings, the two L-shaped flanges **496** and **516** define an I-section such that foot portions **500** and **520** may be referred to as forward flanges **500** and **520** like first and second forward flanges **280** and **282** defined by guide beam **268**. Thus, the two L-shaped flanges **496** and **516** may be said to define a guide beam **522** with first and second forward flanges **500** and **520** which will be engaged by forward and rear rollers **314** and **316** in the same manner as first and second forward flanges **280** and **282**. Thus, wellhead isolation tool **10** may include either support structure **200** or support structure **400**. The operation of the wellhead isolation tool **10** is as described herein with both embodiments of the support structures described.

While numerous changes to the apparatus and methods can be made by those skilled in the art, such changes are encompassed within the spirit of this invention as defined by the appended claims.

What is claimed is:

1. A wellhead isolation tool for injecting substances through a wellhead into a well, the wellhead defining a longitudinal passage therethrough, the wellhead isolation tool comprising:

a mandrel defining a mandrel flow passage therethrough and having a non-threaded outer surface, the mandrel having upper and lower ends;

a sealing device at the lower end of the mandrel for sealingly engaging an element in the well;

at least one valve connected to the upper end of the mandrel, wherein the substances to be injected into the well may be communicated through the at least one valve into the mandrel flow passage when the at least one valve is in an open position;

a threaded drive rod for reciprocating the mandrel through the wellhead into and out of the well, the threaded drive rod being vertically aligned with the mandrel; and
a coupling for connecting the at least one valve to the threaded drive rod.

2. The wellhead isolation tool of claim 1, wherein the sealing device comprises a cup seal.

3. The wellhead isolation tool of claim 2, wherein the sealing device further comprises a cup mandrel threadedly connected to the lower end of the mandrel, the cup seal being disposed about the cup mandrel.

4. The wellhead isolation tool of claim 1, wherein the sealing device comprises a diffuser.

5. The wellhead isolation tool of claim 1, wherein the threaded drive rod moves vertically to move the mandrel through the wellhead.

6. The wellhead isolation tool of claim 1, further comprising a drive mechanism for moving the threaded drive rod vertically to move the mandrel.

7. The wellhead isolation tool of claim 1, further comprising a support structure for supporting the mandrel and the at least one valve above the wellhead.

8. The wellhead isolation tool of claim 7, wherein the support structure comprises:

a lower support plate;

at least one support leg extending upwardly from the lower support plate; and

11

an upper support plate connected to an upper end of the at least one support leg.

9. The wellhead isolation tool of claim 8, wherein the support structure further comprises a vertically oriented guide beam for guiding the mandrel, and wherein the wellhead isolation tool further comprises a roller assembly operably associated with the mandrel and engageable with the guide beam for guiding the mandrel and the at least one valve.

10. The wellhead isolation tool of claim 9, wherein the roller assembly is connected to the at least one valve.

11. The wellhead isolation tool of claim 8, further comprising a lower hub defining a passage therethrough, the lower support plate being connected to the lower hub when the mandrel is being reciprocated in or out of the well through the wellhead.

12. The wellhead isolation tool of claim 11, wherein the lower hub comprises a body portion and upper and lower flanges extending outwardly therefrom, the upper and lower flanges defining a space therebetween, and wherein the lower support plate is received between the upper and lower flanges.

13. The wellhead isolation tool of claim 12, wherein the lower support plate has a generally U-shaped cutout adapted to be disposed about the body portion of the lower hub.

14. The wellhead isolation tool of claim 13, wherein the lower support plate has at least one opening therethrough, and wherein the upper and lower flanges of the lower hub have corresponding openings therethrough so that a pin may be inserted through the upper and lower flanges and the lower support plate to connect the lower support plate to the lower hub.

15. A wellhead isolation tool for injecting substances through a passage defined by a wellhead into a well, the wellhead isolation tool comprising:

- a mandrel defining a mandrel passage, the mandrel having an outer surface and a longitudinal central axis;
- a valve connected to an upper end of the mandrel, the valve having an open and a closed position, wherein the substances to be injected may be communicated through the valve into the mandrel passage when the valve is in the open position;
- a threaded drive rod positioned above the valve and operably associated therewith, so that up-and-down movement of the threaded drive rod causes the mandrel to reciprocate in and out of the well through the passage defined by the wellhead, the threaded rod being coaxial with the mandrel; and
- a drive mechanism for moving the threaded drive rod vertically so that the mandrel is moved in and out of the well.

16. The wellhead isolation tool of claim 15, further comprising a sealing device at a lower end of the mandrel for sealingly engaging an element in the well when the mandrel is received in the well through the wellhead.

17. The wellhead isolation tool of claim 15, wherein the drive mechanism comprises a mechanically driven screw-jack.

18. The wellhead isolation tool of claim 15, further comprising a support structure for supporting the mandrel as the mandrel is moved in or out of the well.

19. The wellhead isolation tool of claim 18, wherein the support structure comprises:

- an upper support plate;
- a lower support plate; and
- a plurality of supports legs connected at the upper ends thereof to the upper support plate and at the lower ends thereof to the lower support plate.

12

20. The wellhead isolation tool of claim 15, further comprising:

- a wellhead adapter for connecting the wellhead isolation tool to the wellhead, the wellhead adapter having threads at a lower end thereof; and
- a wellhead adapter sub adapted to connect to the wellhead, the wellhead adapter sub having threads thereon for connecting to the threads on the wellhead adapter.

21. The wellhead isolation tool of claim 20, wherein the wellhead adapter sub comprises:

- a mounting plate having a plurality of openings adapted to mate with a bolt pattern on the wellhead; and
- a threaded neck extending upwardly from the mounting plate.

22. A wellhead isolation tool for injecting substances through a wellhead into a well, the wellhead defining a longitudinal passage therethrough, the wellhead isolation tool comprising:

- a mandrel defining a mandrel flow passage for the substances to be injected, the mandrel having a lower end sealingly engageable with a tubular element in the well;
- at least one valve connected to an upper end of the mandrel, wherein the substances may be communicated into the mandrel flow passage when the at least one valve is in an open position;
- a drive rod releasably connected to the at least one valve for reciprocating the mandrel into and out of the well through the longitudinal passage in the wellhead;
- a lower hub having a passage through which the mandrel passes;
- a wellhead adapter connected to the lower hub for connection to the wellhead; and
- a removable support structure for supporting the at least one valve and the mandrel while the mandrel is urged through the wellhead, the support structure comprising:
 - a lower support plate having a vertical support member extending upwardly therefrom, the lower support plate defining a plurality of openings therethrough, the lower hub having a plurality of mating openings, wherein pins may be removably inserted into the openings in the lower hub and the lower support plate, and wherein the support structure may be disconnected and removed by removing the pins and disconnecting the drive rod from the at least one valve after the wellhead adapter is connected to the wellhead.

23. The wellhead isolation tool of claim 22, wherein the wellhead adapter has threads thereon for connecting to threads on a wellhead adapter sub adapted to connect to and extend upwardly from the wellhead.

24. The wellhead isolation tool of claim 23, wherein the wellhead adapter sub has a hole pattern adapted to mate with a bolt pattern on an upper end of the wellhead.

25. The wellhead isolation tool of claim 22, wherein the lower support plate has a generally U-shaped cutout, the cutout being received about a body portion of the lower hub.

26. The wellhead isolation tool of claim 25, wherein the lower hub comprises upper and lower flanges extending radially outwardly from the body portion, and wherein the lower support plate is received between the upper and lower flanges.

27. The wellhead isolation tool of claim 25, wherein the support structure comprises an upper support plate connected to an upper end of the vertical support member, the upper support plate being identical to the lower support plate.

13

28. The wellhead isolation tool of claim 27, further comprising an upper hub connected to the upper support plate, wherein the drive rod passes through the upper hub.

29. A wellhead isolation tool comprising:

- a mandrel for reciprocating through a wellhead into a tubular element disposed in a well below the wellhead;
- a valve connected to the mandrel and movable therewith;
- a wellhead adapter for connecting the wellhead isolation tool to the wellhead, wherein the mandrel is movable in the wellhead adapter; and
- a wellhead adapter sub, the wellhead adapter sub having a bolt hole pattern adapted to match a bolt pattern on an upper end of the wellhead, the wellhead adapter sub having a threaded upper end for mating with threads on the wellhead adapter so that the wellhead adapter sub may be bolted to the wellhead, wherein the wellhead isolation tool may be connected to the wellhead by threadedly connecting the wellhead adapter to the wellhead adapter sub.

30. The wellhead isolation tool of claim 29, wherein the threads on the wellhead adapter comprise internal threads, and wherein the threads on the wellhead adapter sub comprise external threads.

31. The wellhead isolation tool of claim 29, wherein the wellhead adapter comprises a wellhead adapter housing and a wing nut connected to a lower end of the wellhead adapter housing, the wing nut having threads defined thereon.

32. The wellhead isolation tool of claim 29, further comprising a support structure for supporting the valve and the mandrel as the mandrel is moved through the wellhead into the well.

33. The wellhead isolation tool of claim 32, wherein the support structure comprises a vertically oriented beam, and wherein the wellhead isolation tool further comprises a roller assembly engageable with the vertically oriented beam for guiding the mandrel and the valve.

34. The wellhead isolation tool of claim 33, wherein the roller assembly is connected to the valve.

35. The wellhead isolation tool of claim 29, further comprising a drive rod for vertically moving the mandrel.

36. The wellhead isolation tool of claim 35, wherein the drive rod is a threaded drive rod, and wherein the wellhead isolation tool further comprises a drive mechanism for moving the drive rod.

37. The wellhead isolation tool of claim 35, wherein the drive rod and the mandrel have a common longitudinal axis.

38. A wellhead isolation tool for injecting substances through a passage defined by a wellhead into a well, the wellhead isolation tool comprising:

- a mandrel defining a mandrel flow passage for the substances to be injected, the mandrel being movable between an upper position wherein the mandrel is retracted from the wellhead and a lower position wherein a lower end of the mandrel is received in an element in the well;
- a valve connected to the mandrel and movable therewith;
- a drive rod connected to the valve for moving the mandrel between its upper and lower positions;
- an upper hub, the drive rod being movably disposed in the upper hub;
- a lower hub, the mandrel being movably disposed in the lower hub;
- a wellhead adapter that connects the lower hub to the wellhead; and
- a support structure for supporting the mandrel as the mandrel is being inserted into or withdrawn from the well through the wellhead, the support structure comprising:

14

an upper support plate connectable to the upper hub; a lower support plate releasably connectable to the lower hub; and

a vertical support frame connected to the upper and lower support plates, wherein the lower support plate, the upper hub, the drive rod, and the support structure can be moved as a unit after the mandrel is moved to its lower position by disconnecting the lower support plate from the lower hub and releasing the drive rod from the valve.

39. The wellhead isolation tool of claim 38, wherein the vertical support frame comprises a plurality of vertical support legs connected to the upper and lower support plates.

40. The wellhead isolation tool of claim 38, wherein the vertical support frame has a left side, a right side, and a rear side, and wherein a plurality of access openings are defined in each of the left, right, and rear sides of the vertical support frame.

41. The wellhead isolation tool of claim 40, wherein the vertical support frame defines a generally rectangular periphery, the vertical support frame having an open front side.

42. The wellhead isolation tool of claim 40, wherein the vertical support frame comprises a pair of connected frame portions, each frame portion defining one of the left and right sides and a portion of the rear side of the vertical support frame.

43. The wellhead isolation tool of claim 42, further comprising a roller assembly connected to the valve, wherein the pair of frame portions define a vertical guide beam, and wherein the roller assembly engages the guide beam to guide the mandrel in and out of the well.

44. The wellhead isolation tool of claim 43, wherein the lower support plate may be disconnected from the lower hub, and wherein the support structure, the upper hub, and the drive rod may be moved as a unit.

45. A wellhead isolation tool for injecting substances through a passage defined by a wellhead into a well, the wellhead isolation tool comprising:

- an upper hub;
- a drive rod movably disposed in the upper hub;
- at least one valve releasably connected to the drive rod;
- a mandrel defining a flow passage positioned below the at least one valve, the at least one valve having a closed position and an open position, wherein in the open position the substances to be injected may be communicated through the at least one valve into the mandrel;
- a lower hub, the mandrel being movably disposed in the lower hub;
- a wellhead adapter for connecting the lower hub to the wellhead; and
- a support structure comprising:
 - an upper support plate releasably connected to the upper hub;
 - a lower support plate releasably connected to the lower hub; and
 - a support frame extending between the upper and lower support plates, wherein the support frame has an outer periphery defining a generally rectangular cross section having a left side, a right side, a rear, and a front.

46. The wellhead isolation tool of claim 45, wherein the support frame defines a guide beam, wherein the wellhead isolation tool further comprises a roller assembly, and wherein the roller assembly engages the guide beam to guide the mandrel in and out of the well.

15

47. The wellhead isolation tool of claim **45**, wherein the support frame comprises first and second frame halves connected together.

48. The wellhead isolation tool of claim **47**, wherein each frame half comprises a bent metal plate.

49. The wellhead isolation tool of claim **48**, wherein each frame half further comprises:

a side panel;

a rear panel;

16

and a generally L-shaped flange extending from an inner edge of the rear panel, wherein the L-shaped flanges define the guide beam when the frame halves are connected together.

⁵ **50.** The apparatus of claim **45**, wherein the left and right sides and the rear of the support frame define a plurality of access opening.

* * * * *