

March 28, 1967

G. NUSSBAUM-CHRISTMANN

3,310,916

COMPOSITE ABRASIVE GRINDSTONES

Filed Aug. 24, 1964

2 Sheets-Sheet 1

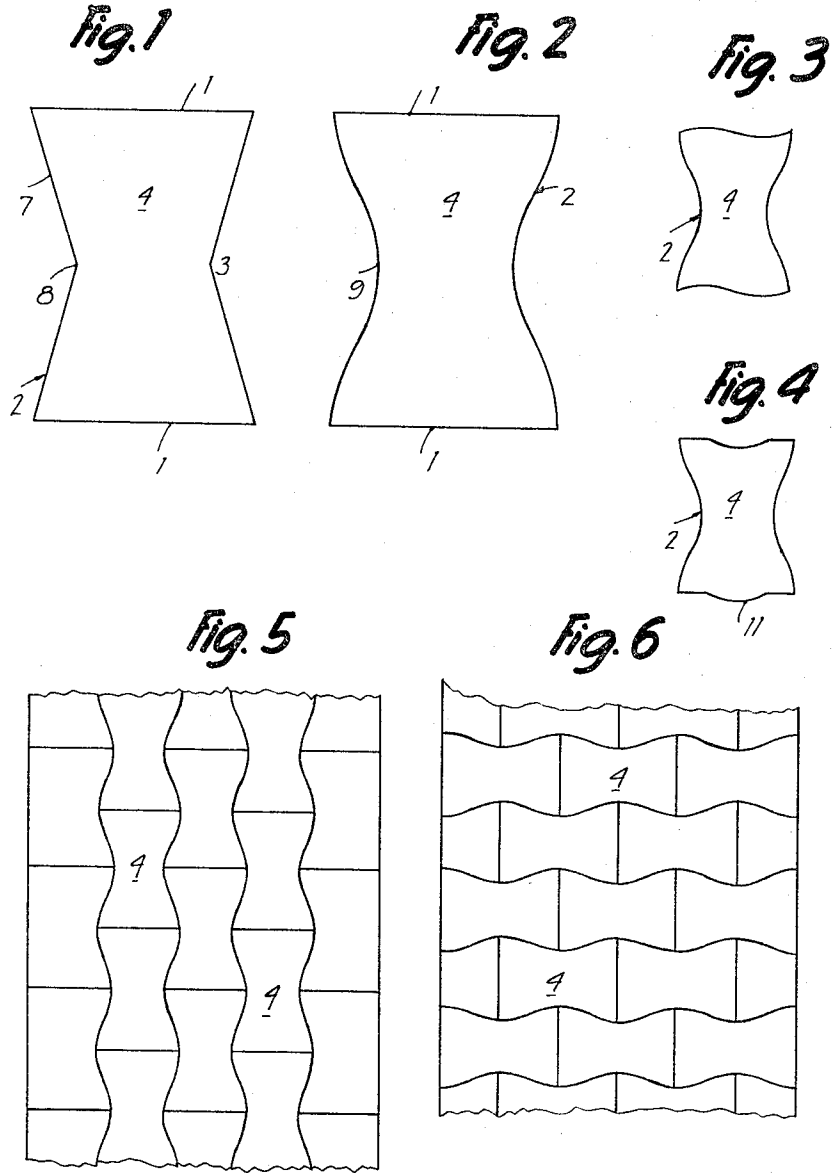

INVENTOR.  
Guillermo Nussbaum-  
Christmann  
BY  
Michael J. Striker  
12/11/67

March 28, 1967

G. NUSSBAUM-CHRISTMANN

3,310,916

COMPOSITE ABRASIVE GRINDSTONES

Filed Aug. 24, 1964

2 Sheets-Sheet 2

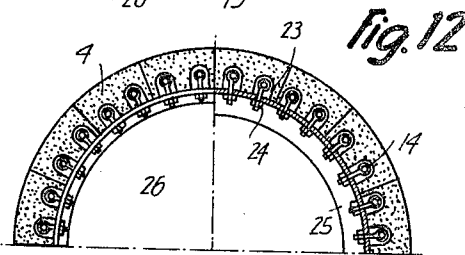
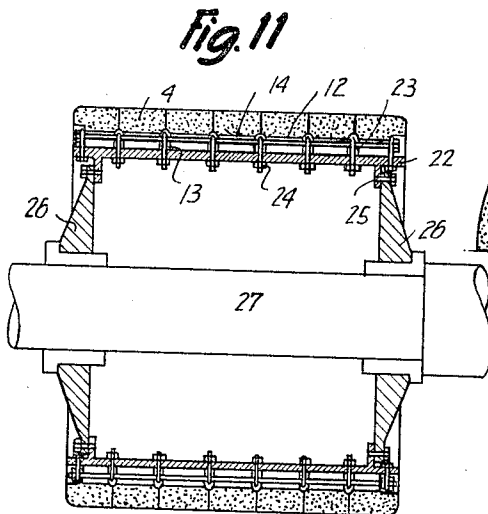
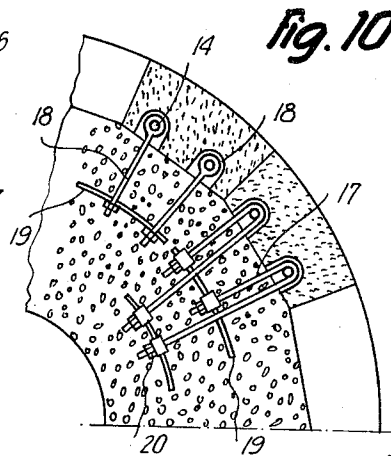
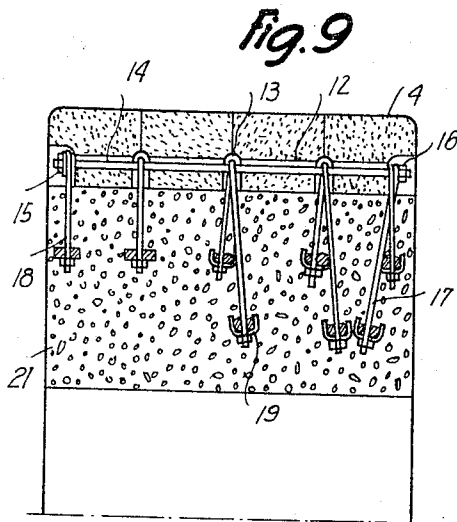
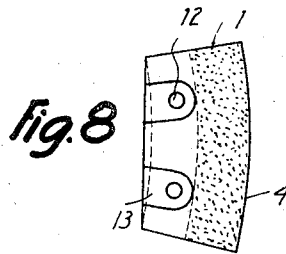
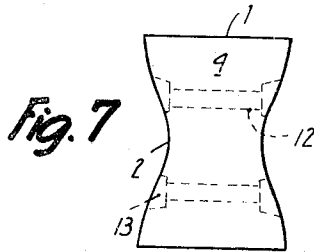

INVENTOR.

G. Nussbaum-Christmann

BY

Michael J. Striker

Attorney

1

3,310,916

**COMPOSITE ABRASIVE GRINDSTONES**

Guillermo Nussbaum-Christmann, Calle Paz 24, Caldas de Estrach, Barcelona, Spain

Filed Aug. 24, 1964, Ser. No. 391,421

Claims priority, application Spain, Apr. 11, 1964, 298,929

7 Claims. (Cl. 51-206.5)

This invention relates to composite grindstones used for various abrasive operations.

Conventionally, composite grindstones are manufactured by an appropriate composition of ceramic sectors of a cylinder which are usually mounted on reinforced concrete cores and which are held together by pins anchored in the concrete mass of the cores. In one known construction, the sectors are polygonal in shape, as a rule hexagonal, when viewed looking at the cylindrical surface along a radius of the grindstone, in order not to form continuously straight bonds or joints, with the possibility of disturbingly uneven wear. A composite grindstone of this kind is free from many of the disadvantages of the grindstones which preceded it, but it still has the disadvantage that the sectors are not held together satisfactorily and tend to separate because their inclined adjacent surfaces have a wedging action upon each other when a work load is applied to them.

Anchoring the sectors to a reinforced concrete core also has disadvantages. The concrete forming the core may crack and the anchor pins work loose, or heat variations occurring during operation may lead to differential expansion between steel pins and the ceramic materials used for the grindstone, with the result that separations occur between the central body and the sectors and lead to vibrations, cracks, and breakages.

The object of this invention is to provide an improved composite ceramic grindstone.

According to the invention, a composite abrasive grindstone comprising segments of a cylinder providing the operative surface, is characterised in that such sectors have a shape, when viewed radially of the grindstone, having a waisted central zone separating two widened end zones with side walls of complementary shapes whereby adjacent sectors interlock with one another and assist each other to withstand tangential forces, the sectors being maintained in position by compressing means which act in an axial direction of the grindstone and which are secured radially to central framing in the grindstone.

The segments have a geometric shape such that when a number of sectors are combined to form a cylindrical grindstone they engage with one another and retain one another by lateral pressure or radial tension, the joints in their side surfaces being wavy and offset at their ends.

A prestressed radial or circular metal framework directly retains the grindstone-forming sectors and can withstand the centrifugal and tangential forces arising during operation and is resilient enough to compensate for stresses produced by dimensional variations caused by heat.

In a preferred form of the invention, the sectors are provided with continuous passages which are aligned with one another in the axial direction of the grindstone in the assembled grindstone, and which receive in their interior bracing members which form the compressing means, lateral grooves extending radially inwards from such passages and receiving radial bracing members which are connected to the central framing. Preferably, the central framing comprises members in the form of annular elements which can be occluded, together with the radial bracing members, in a mass of concrete; in this case, it is very advantageous to use prestressing tech-

2

niques to pretension the bracing members before said occlusion.

As a variant, the central framing can be in the form of a hollow cylinder to which the inward ends of the radial bracing members are secured and which acts as a support member for the sectors.

Embodiments of the invention are shown in the accompanying drawings, wherein:

FIGS. 1, 2, 3 and 4 show four variants of sectors, in elevation looking at their operative surfaces;

FIGS. 5 and 6 are developed views of part of a grindstone surface, showing how such segments are arranged;

FIGS. 7 and 8 are, respectively, a facial elevation and an end elevation, partly in section on a radial plane, of one practical form of sector;

FIG. 9 is half of a longitudinal section, on an axial plane, of a grindstone;

FIG. 10 is a partial cross-section corresponding to FIG. 9;

FIG. 11 is a longitudinal section, on an axial plane, of a modified grindstone; and

FIG. 12 is a half cross-section, on two different planes, corresponding to FIG. 11.

All the sectors shown in FIGS. 1 to 9 have an external working surface which is part of a cylinder, and are formed by elongated ceramic members having end walls 1 and side walls 2, the side walls 2 having a waisted part 3 located medially between the ends 1 to provide the overlapping bonding shown in FIGS. 5 and 6 to provide a grindstone having a cylindrical working surface.

In the segment shown in FIG. 1, the side walls 2 are formed by planar parts 7 which converge at 8 to provide the waist 3.

In the embodiments shown in FIGS. 2, 3 and 4, the walls 2, at their ends adjacent the end walls 1 and at the waist 3, are rounded as at 9 (FIG. 2) to give a substantially sinusoidal development repeated around the grindstone periphery when the sectors are assembled as in FIG. 5.

In the embodiment shown in FIG. 3 the end walls also are sinusoidal, as at 10, whilst in the embodiment shown in FIG. 10 the two end walls have, respectively, complementary recesses and projections 11.

All the sectors shown can be assembled to form the mosaics shown in developed form in FIGS. 5 and 6. In FIG. 5 the sectors are disposed with the side walls extending around the periphery or working surface of a grindstone at an angle to a plane extending normal to the axis of rotation of the grindstone, while in FIG. 6 the side walls of the sectors are disposed laterally of said surface.

A practical form of sector is shown in FIGS. 7 and 8. As will be apparent, the sectors are formed with transverse passages 12 so located that the passages in laterally adjacent sectors are aligned as shown in FIGS. 9 and 11. The ends of the passages 12, at the side walls 2, are enlarged as at 13.

In the grindstones shown in FIGS. 9-12, the sectors are arranged as a tubular group and are secured together by means of longitudinal members 14 which extend through the aligned passages 12 in the sectors and which are secured at the axial ends of the grindstone by means of nuts 15 and 16.

In the form shown in FIGS. 9 and 10 the members 14 are braced radially by means of members 17 which have a U-shape, and members 18 which have a terminal lug, and which are anchored to ring portions 19, which form central frame members, through the agency of nuts 20.

The members 14 can be replaced by any other means providing axial compression.

This rigid assembly, which may or may not be pre-

tensioned, is embedded into a mass 21, which may be concrete, and which gives the grindstone the required weight and the means for assembling the same in the mechanism where the grindstone is to be used.

In the embodiment shown in FIGS. 11 and 12, the sector-mounting means takes the form of a metal cylinder 22 to which the longitudinal members 14 are anchored by means of short stirrup-shaped members 23 and nuts 24 which bear against the inside surface of the cylinder 22. Through the agency of inwardly directed flanges 25 at the ends of the cylinder 22, the mounting means can be secured to two end plates 26 which are secured by conventional means to a shaft 27. The metal cylinder 22 may act as a support means for the sectors.

A study of the drawings will show the simplicity of this novel construction for large abrasive grindstones, and the strength of the assembly once assembled. Nor does the system lack any of the advantages of the prior art grindstones, and a worn grindstone can readily be replaced, since all that is required is to replace the operative surface formed by the sectors.

What I claim and desire to secure by Letters Patent is:

1. A composite abrasive rotary grindstone of substantially cylindrical configuration, comprising a plurality of sectors together constituting a tubular outer shell of said grindstone having spaced axial ends and a grinding surface intermediate said ends, each of said sectors having a pair of spaced endfaces and a pair of sidefaces extending between said endfaces, and all such faces as are located inwardly of said axial ends of said shell being at an angle to a plane extending normal to the axis of rotation of said grindstone; and securing means securing said sectors against relative movement in axial and radial direction of said grindstone.

2. A grindstone as defined in claim 1, wherein said sectors are each provided with at least one passage, the

passages of sectors arranged in axial direction of said grindstone being aligned; and wherein said securing means comprises bracing rods located in the respective aligned passages and secured to the respective axially outermost sectors.

3. A grindstone as defined in claim 1, wherein said sectors are each further provided with at least one groove extending transversely of the respective passage toward the interior of said shell; and wherein said securing means further comprises support means arranged inwardly of said shell and connecting members extending through said grooves and secured to the respective bracing rods and support means, respectively.

4. A grindstone according to claim 3, wherein said support means comprises annular elements.

5. A grindstone according to claim 4, wherein said annular elements and said connecting members are occluded in a mass of concrete.

6. A grindstone according to claim 5, wherein said connecting members are placed in tension before being occluded in said mass of concrete.

7. A grindstone according to claim 3, wherein said securing means comprises a hollow cylinder to which the inner ends of said connecting members are secured and which acts to support the sectors.

#### References Cited by the Examiner

##### UNITED STATES PATENTS

2,032,484 3/1936 Jeppson ----- 51-206.5

##### FOREIGN PATENTS

319,469 9/1929 Great Britain.

ROBERT C. RIORDON, *Primary Examiner.*

D. G. KELLY, L. S. SELMAN, *Assistant Examiners.*