

Jan. 13, 1925.

1,522,949

V. H. EMERSON

METHOD OF MAKING SOUND RECORDS

Filed Aug. 11, 1920

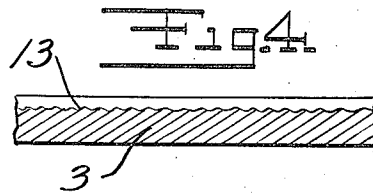
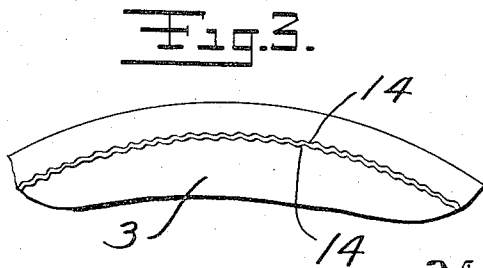
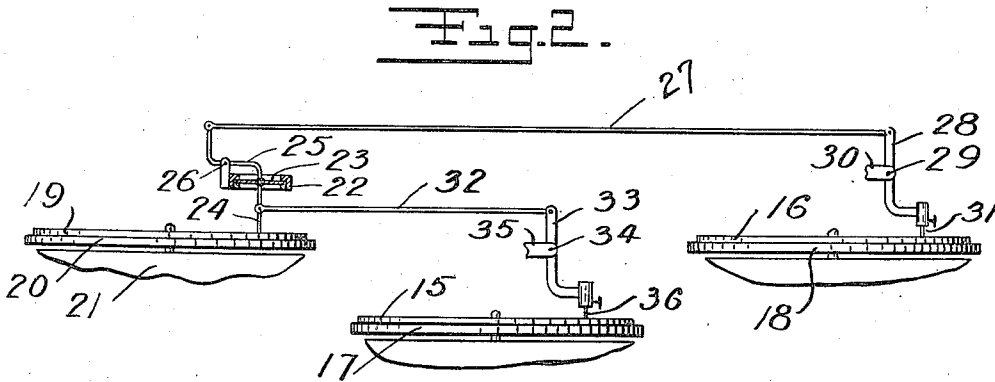
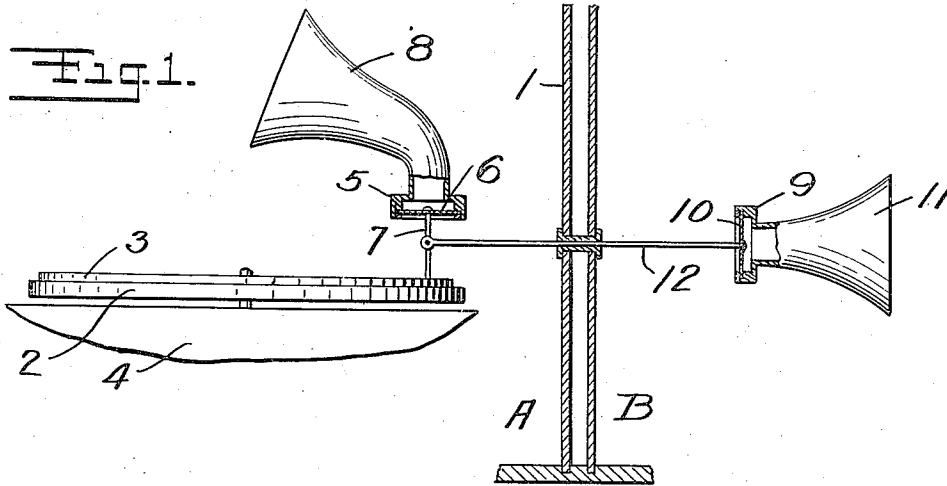

Victor H. Emerson, Inventor

By his Attorney

W. J. Emerson

UNITED STATES PATENT OFFICE.

VICTOR H. EMERSON, OF NEW YORK, N. Y., ASSIGNOR TO EMERSON PHONOGRAPH COMPANY, INC., OF NEW YORK, N. Y., A CORPORATION OF NEW YORK.

METHOD OF MAKING SOUND RECORDS.

Application filed August 11, 1920. Serial No. 402,874.

To all whom it may concern:

Be it known that I, VICTOR H. EMERSON, a citizen of the United States, residing at the city, county, and State of New York, have invented new and useful Improvements in a Method of Making Sound Records, of which the following is a specification.

My invention relates to phonograph records and more particularly to methods for recording whereby a plurality of records may be made in the space heretofore occupied by a single record.

Various attempts have heretofore been made to increase the linear recording space available on a given size of sound record disk so as to utilize more effectively the existing space, all of which attempts gave unsatisfactory results. The linear recording space at most could only be slightly increased by the methods of these attempts, and the increased utilization of existing space was only accomplished by means of complicated and expensive recording and reproducing machines, and the records so produced could not be played upon existing machines in common use. An object of my invention is to provide a sound record, the recording capacity of which, for any given size, is very greatly increased, which can be economically produced in quantities by the usual method of stamping the blanks with master record dies, and which can be played upon existing reproducing or talking machines in common use. A further object is to provide a novel recording method by which such records can be produced. Other objects and advantages will be apparent from the following description and the novel features of my invention will be particularly pointed out in claims.

My invention contemplates the production of record disk having therein a record groove that simultaneously undulates in a plurality of different directions, such as for example both laterally and vertically, the lateral undulations in the example given constituting one recording, and the vertical undulations another and different recording. These records can be reproduced independently by a machine having a sound box positioned to be actuated by either the lateral or by the vertical undulations, and the undulations other than those being reproduced at any time will be ineffective upon that

particular reproduction. My invention further contemplates a recording method for such records wherein the recording stylus is concomitantly given movements in a plurality of different directions, such as both laterally and vertically undulating movements, each representing and corresponding to different and independent selections.

In the accompanying drawings,

Figure 1 is a schematic illustration of one form of apparatus by means of which my method may be practiced.

Fig. 2 is a schematic illustration of a modified form of apparatus.

Fig. 3 is a plan of a portion of a record produced by the practice of my invention, and

Fig. 4 is a sectional elevation taken along one of the record grooves in order to illustrate the vertical undulations therein.

Referring particularly to Fig. 1 of the drawing, I may provide two adjacent recording rooms A and B, having a sound proof partition 1 between them. In one of the rooms, A, I provide a record turntable or support 2, which carries a record blank 3. The table 2 is given a combined rotary and translatory movement by mechanism well known in the art, and which for the purpose of explanation may be schematically illustrated as a motor 4. A sound box 5 is supported in any suitable manner adjacent the record blank, and is provided with a suitable diaphragm 6, and a recording stylus 7 carried by the diaphragm. A horn or sound condensing or intensifying conduit 8 leads to the sound box 5 so that sound waves produced in the room A and entering the conduit or horn 8, will be intensified and conducted to the interior of the sound box where they will impinge upon and set into vibration the diaphragm 6. The vibrations of the diaphragm will cause the recording stylus 7, attached thereto, to move vertically and a record groove will be cut in the record blank which will undulate vertically in accordance with the sound waves impinging upon the diaphragm. This groove is what is known as a vertically or perpendicularly undulating record groove, also often called a hill and dale record because of the miniature hills and dales formed in the bottom of the record groove.

In the room B I mount in any suitable manner another sound box 9 carrying a vi-

bratory diaphragm 10, and having a recording horn or sound intensifying conduit 11 leading thereto, so that if sound waves are produced in the room B, those waves entering the horn or intensifying conduit 11 will impinge upon and cause corresponding vibrations of the diaphragm 10. The diaphragm 10 of sound box 9 is connected with the recording stylus 7 of the sound box 5 by a suitable connection 12, which passes through the sound proof partition 1. The connector 12 is disposed substantially at right angles to the stylus 7 and its normal direction of movement under the influence of the diaphragm 6. Thus the sound waves impinging upon the diaphragm 10 in the room B will be transmitted through the connection 12 to the stylus 7 and the latter will be given lateral vibrations or movements corresponding to the sound waves being produced in room B and as the sound record blank moves under the stylus, the blank will have produced therein a zig-zag or laterally undulating groove, the undulations of which correspond to the sound waves produced in the room B. The lateral vibrations of the stylus 7 can be produced by the connector 12 and diaphragm 10 irrespective of whether or not it is being concomitantly operated in a vertical direction by the diaphragm 6 of the sound box 5. Likewise the stylus can be given its vertical vibrations regardless of whether or not it is being also vibrated laterally by connector 12 and diaphragm 10. If the diaphragm 6 only is operating the stylus 7, a pure hill and dale or vertically undulating record groove will be produced in the record blank 3. If the diaphragm 10 only is operating the stylus a pure zig-zag or laterally undulatory record groove will be produced in the blank which partakes of the nature of both forms of grooves and will undulate both vertically and laterally. The side walls of the groove will undulate to correspond to the sound vibrations or waves produced in the room B and the bottom wall will undulate to correspond to the sound waves produced in the room A. The sound waves produced in room B may be, and preferably are, entirely unrelated or different from those produced in room A, so that each groove contains the record of two entirely different and distinct selections. If a record produced in this manner is played upon a machine designed to play laterally undulatory or zig-zag records, also called lateral cut records, the vertical undulations will be ineffective upon the diaphragm of the reproducing sound box and the box will merely float up and down. The lateral undulations of the groove, however, will be effective upon the reproducing stylus to vibrate it and the diaphragm to which it is connected, and the sounds produced will correspond to those which were produced in the room B

during the recording operation. Likewise, if the record so produced is played upon the so-called hill and dale reproducing machine, the lateral undulations will merely oscillate the sound box laterally bodily and will be ineffective in producing movements of the diaphragm, while the vertical undulations of the grooves will produce vibrations of the reproducing stylus and diaphragm, and the sounds produced will correspond to those which were produced in the room A at the time the record was made. The vertical undulations of the bottom wall 13 of the groove are illustrated in Fig. 4, and the lateral undulations of the side walls 14 of the groove are illustrated in Fig. 3.

I have thus far described in more or less detail the application of my invention to original or first hand recording requiring separate sound isolated rooms.

In the practice of my invention therefore I prefer to first record each selection independently in the manner now commonly employed, and these records are then transferred to the record having the combined groove. To accomplish this transfer (see Fig. 2) the individual records 15 and 16 having their one particular selection recorded thereon are mounted on record supports or tables 17 and 18, respectively, by which they are given a rotary and common translatory movement. Adjacent thereto, the record blank 19 which is to receive the combined record grooves is supported by a table 20, by means of which it is given a rotary movement and also a translatory movement similar and concomitantly to that given the tables 17, 18. Thus the three tables 17, 18 and 20 will rotate and also move in the same direction concomitantly. Or, if desired, the tables may have no translatory movement and the transfer mechanism can be given the translatory movement. It is only necessary that there be relative translatory movement between the record tables and the transfer mechanism where the record is to be spirally cut. The table may receive its rotary movement in any suitable manner and a source of power for such movement is schematically designated as a motor 21. Over the record blank 19 is disposed the box 22, the diaphragm 23 of which is provided with a recording stylus 24. The sound box 22 is disposed so that vibratory movement of the diaphragm 23 will cause a vertical movement of the recording stylus which will cut a vertically undulating record groove in the record blank. A bell crank lever 25 is pivoted at 26 to the sound box 22 and has one arm bearing upon the diaphragm to impart downward vibratory movement thereto. The other arm of the bell crank 25 is connected by a connection 27 to the stylus arm 28, pivoted at 29 to a suitable support 30. The stylus arm 28 carries at one end a re-

producing stylus 31 which tracks in the record groove of the record 16. Thus, vibratory movement of the stylus 31 will be transmitted to the stylus 24 and impressed or cut into the record blank 19 as a hill and dale or vertically undulatory groove. A connector 32 is attached to the stylus 24, and extends laterally thereof and is connected to an arm of a stylus bar 33 which is pivotally connected at 34 to a suitable support 35. The bar 33 carries a reproducing stylus 36 at one end which is disposed to track in the record grooves of the record 15. Thus the vibrations of the bar 33, which it receives from the record 15, will be transmitted to the stylus 24 to cause lateral vibrations thereof and cause it to cut a zig-zag or laterally undulatory groove in the record blank 19. Thus the two movements imparted to the stylus 24 will cause it to cut a record groove which is both laterally and vertically undulatory, being a combination of the two movements. The groove so produced will correspond to that produced by the method explained in connection with Fig. 1. The supports 30 and 35 and sound box 22 will be connected to move together if the transmitting parts are to move with respect to the record supports. It will be seen that the record produced by this method may have substantially the same number of record grooves as those now commonly manufactured and each groove has two different and distinct selections therein which can be independently repro-

duced on existing machines now in common use which are adapted to selectively play either hill and dale or laterally undulating (zig-zag) records. For any given size record, therefore, I have in my invention practically doubled its capacity for receiving and recording any information or selections without materially increasing the cost of manufacture.

The herein described apparatus is intended as illustrative only of one way in which my invention may be practiced, and it is obvious that various changes in the details herein described and illustrated may be made within the principle and scope of the invention.

Having described my invention, what I claim is:

The herein described method of making sound records which comprises producing relative movement between a record blank and recording stylus to form a record groove, imparting to the stylus a movement in one direction to cause undulations in the record groove corresponding to those of one pattern record, and concomitantly imparting to the same stylus a movement in another direction to cause undulations in the same record groove corresponding to those of another and different pattern record.

In testimony whereof I have hereunto set my hand.

VICTOR H. EMERSON.