



Europäisches Patentamt
European Patent Office
Office européen des brevets



(11) **EP 1 442 101 B1**

(12) **EUROPEAN PATENT SPECIFICATION**

(45) Date of publication and mention
of the grant of the patent:

03.08.2005 Bulletin 2005/31

(21) Application number: **02787423.9**

(22) Date of filing: **05.11.2002**

(51) Int Cl.7: **C10J 3/26**

(86) International application number:
PCT/DK2002/000744

(87) International publication number:
WO 2003/040267 (15.05.2003 Gazette 2003/20)

(54) **A PROCESS AND GASIFIER FOR GASIFICATION OF SOLID BIOFUEL**

VERFAHREN UND VERGASER ZUM VERGASEN VON FESTEM BIOBRENNSTOFF

PROCEDE ET DISPOSITIF SERVANT A GAZEIFIER UN BIOCOMBUSTIBLE SOLIDE

(84) Designated Contracting States:
**AT BE BG CH CY CZ DE DK EE ES FI FR GB GR
IE IT LI LU MC NL PT SE SK TR**

(30) Priority: **05.11.2001 DK 200101638**

(43) Date of publication of application:
04.08.2004 Bulletin 2004/32

(73) Proprietor: **Biosynergi Proces ApS
DK-2970 Horsholm (DK)**

(72) Inventor: **JAKOBSEN, Henrik, Houmann
DK-2970 Horsholm (DK)**

(74) Representative: **Englev, Peter et al
c/o Chas. Hude A/S
33. H.C. Andersens Boulevard
1780 Copenhagen V (DK)**

(56) References cited:
**CA-A- 1 208 911 DK-B- 172 277
NL-A- 8 900 939 US-A- 1 821 263
US-A- 4 459 136**

- **REED THOMAS B. ET AL: HANDBOOK OF
BIOMASS DOWNDRAFT GASIFIER ENGINE
SYSTEMS, 1988, pages 38-42, XP002236114
Biomass Energy Foundation Press GOLDEN,
COLO.**

EP 1 442 101 B1

Note: Within nine months from the publication of the mention of the grant of the European patent, any person may give notice to the European Patent Office of opposition to the European patent granted. Notice of opposition shall be filed in a written reasoned statement. It shall not be deemed to have been filed until the opposition fee has been paid. (Art. 99(1) European Patent Convention).

DescriptionTechnical field

5 **[0001]** The present invention relates to a process for gasification of solid, moderately flowable biofuel in a downdraft gasifier having an open core and a fixed gasification bed wherein the fuel material and primary air are fed at the top so as from the top and downward to pass a) a drying zone, b) a pyrolysis zone, c) a combustion zone involving flaming pyrolysis to which secondary air is added and where the fuel is supported by way of a narrowed portion in the inner cross section of the gasifier, d) a reduction zone and e) optionally an inactive charcoal zone. Furthermore, the present
10 invention relates to a downdraft gasifier to be used in the process and a plant for heat production or a combined heat and power production, said plant including the downdraft gasifier.

Background Art

15 **[0002]** In order to utilise biomass as fuel, the biomass can advantageously be converted into a combustible gas by gasification. Among known biomass gasification processes, downdraft gasification in a stratified gasifier can be mentioned as described in for instance item 5.8 in "The stratified Downdraft Gasifier" in "Handbook of Biomass Downdraft Gasifier Engine Systems" published by Solar Energy Research Institute (SERI), Colorado, USA, (March 1988), pages 38-42.

20 **[0003]** In this gasifier including a cylindrical vessel having an open top air and biomass pass uniformly downward through different zones. In the first zone, air passes through the yet unreacted biomass.

[0004] In the initial stage of the second zone, the biomass reacts with air in flaming pyrolysis during which for instance volatile wood oils burn under the formation of CO₂ and H₂O and supply heat to the pyrolysis process. In the last stage of the second zone, when the oxygen has been consumed, CO and H₂ are formed during continuous pyrolysis and
25 the biomass is converted to charcoal. The total amount of air added in the second zone is thus less than the amount required for a complete (stoichiometric) combustion. The temperature in the second zone usually ranges between 1000 and 1150 °C.

[0005] In the third zone, the process is an adiabatic charcoal gasification in which the hot gases formed during the pyrolysis react with the charcoal during the formation of additional CO and H₂. Accordingly, the solid charcoal is converted by utilising the heat of the gas in order to produce a product gas with a high content of chemical energy and the temperature drops to approx. 800 °C. At the end of the process, the charcoal is completely gasified and the remaining ash drops through a grate provided in the bottom. The product gas produced is also recovered through the grate, the energy thereof being exploitable in a gas combustion process subsequent to purification, e.g. in a cyclone.

[0006] In the above reference from SERI (page 39, right column), it is stated that an advantage of the stratified downdraft gasifier having a cylindrical shape is that it allows for a continuous flow of troublesome biofuel without causing bridging or channelling. Moreover, in connection with bridging it is mentioned in item 5.7.2 (page 34, right column) disclosing the conventional Imbert gasifier having a closed top that bridging and channelling caused by restricting the passage of the fuel at the hearth render high tar output as unpyrolysed biomass drops down into the reaction zone (the reduction zone).

30 **[0007]** DK 172 277 discloses a stratified gasifier in which in addition to the primary gas fed at the top of the gasifier, secondary gas is fed into the pyrolysis zone so as to assist a partial combustion of the pyrolysis gas, a so-called flaming pyrolysis. As in the stratified downdraft gasifier described above, the gasification process in said known gasifier includes at this stage a drying zone, a pyrolysis zone passing into a pyrolysis and combustion zone (flaming pyrolysis), a reduction zone and an inactive charcoal zone. The course of the process is stabilised and controlled indirectly by means
35 of an annular hearth made of a fireproof material to ensure a stable transition between the pyrolysis zone and the flaming pyrolysis in the continuous process. However, while this measure improves the stability, it does not however provide sufficient stability, a temperature level detector with several temperature level areas also being provided as a basis for a complicated temperature adjustment by possibly cooling by injecting water and adjusting the primary air and/or secondary air.
40
45
50

Brief description of the invention

[0008] It has now been found that the process in a downdraft gasifier for gasification of solid, moderately flowable biofuel can be stabilised in a more simple manner by designing the heath surrounding the flaming pyrolysis zone in such a manner that the moderately flowable biofuel provides bridging across the opening of the heath.
55

[0009] The object of the present invention is to provide a process and a gasifier apparatus for continuous downdraft gasification of solid, moderately flowable biofuel rendering good stability regarding the process and maintenance of the position of the individual process zones without a complicated temperature adjustment based on measurements

on several levels.

[0010] This is obtained by a process of the type mentioned above which is characterised by retaining the fuel material by means of the narrowed portion in the flaming pyrolysis (c) through bridging across the opening or openings of the narrowed portion until the material as a result of the partial combustion has been converted into a material having such a flowability that it resumes the downward movement towards the reduction zone.

[0011] Furthermore, the invention relates to a downdraft gasifier having an open core and a fixed gasification bed for the gasification of a solid, moderately flowable biofuel, said gasifier including a reactor having an opening at the top for feeding fuel material and primary air in the following sequence from the top and downward to a) a drying zone, b) a pyrolysis zone, c) a combustion zone involving flaming pyrolysis and having an opening for feeding secondary air and a narrowed portion in the inner cross section of the gasifier, d) a reduction zone, and e) optionally an inactive charcoal zone and a collecting compartment at the bottom of the gasifier having means for removing ash and the fuel gas resulting from the gasification, respectively, said gasifier being characterised in that the narrowed portion in the flaming pyrolysis zone (c) is a hearth having one or more openings dimensioned relative to the biofuel used in such a manner that the fuel material is retained through bridging across the opening or openings of the hearth until the material as a result of the partial combustion has been converted into a material having such a flowability that it resumes the downward movement towards the reduction zone.

[0012] In addition, the invention relates to a plant for heat production or a combined heat and power production including the downdraft gasifier.

[0013] The process and the gasifier according to the present invention are based on the surprising recognition that bridging at the narrowed portion in the cross section of the hearth is advantageous. Hitherto, such a bridging has been considered an undesired feature.

[0014] In the present invention, the change of the physical properties of the fuel material during the course of the pyrolysis process is utilised. Thus the starting material typically comprises relatively large and irregular pieces of material which are easily entangled and which form a bridge at narrowed portions in the downward path of the pieces of material. In the present description and claims, said material is referred to as a "moderately flowable material". During the pyrolysis process said material is converted into a more fine-grained charcoal having a more uniform grain shape resulting in improved flowability and a reduced bridging tendency.

[0015] By utilising this principle, the passage of the material from the flaming pyrolysis zone to the reduction zone, which occurs in free fall, is controlled on the basis of the conversion of the material to flowable charcoal. As a result the vital part of the process becomes self-adjusting and it has turned out that the complicated temperature adjustment based on temperature measurements on several levels, as described in DK 172 277, becomes superfluous.

[0016] In the process according to the invention, the gasified biomass or biofuel can in principle be any combustible, organic material existing as solid, relatively small pieces of material of suitably uniform sizes such that the flowability of the material can be determined in a sufficiently reliable manner. Examples of such materials are various forms of comminute wood in suitable pieces, such as wood chips, shavings, saw dust and wood pellets, which can be made by compressions of comminute wood and saw dust.

[0017] The extent of applicability of the invention appears from the following detailed description. It should, however, be understood that the detailed description and the specific examples are merely included to illustrate the preferred embodiments, and that various alterations and modifications within the scope of protection will be obvious to persons skilled in the art on the basis of the detailed description.

Brief description of the drawings

[0018] The invention is explained in greater detail below with reference to the accompanying drawings, in which

Fig. 1 is a sectional view through a gasifier according to the invention, and

Fig. 2 is a sectional view through an embodiment of a hearth in form of a conical inlet directing sufficiently flowable material down into a cylindrical channel.

Detailed description of the invention

[0019] As shown in Fig. 1, a gasifier is designed as a reactor having an upper cylindrical section 14 with a subjacent collecting compartment 13.

[0020] The cylindrical section has an open top in which the fuel can be fed through an inlet pipe 9. An inlet 11 for primary air is also positioned at the top. In continuation of the inlet pipe 9, a burner tube 1 having a slightly larger sectional area than the inlet pipe 9 is provided. The burner tube 1 ends immediately above a hearth 2 of a heat-stable material and is designed such that the sectional area is narrowed to such an extent that bridging causes the fuel material to be retained.

[0021] In the upper portion of the collecting compartment 13, at a distance below the hearth 2, a grate 3 is provided and means 4 and 8 for collecting and removing ash through a gate 5 are provided below said grate. The product gas generated enters through the grate 3 and is collected in the collecting compartment 13 from where it is recovered through pipe 7 which is led upwards through the cylindrical section and on to be used as fuel gas.

5 [0022] Immediately subjacent to the burner tube 1 and above the hearth 2 a circular inlet 12 for secondary air is provided. In a preferred embodiment, an inlet 6 for a gasification agent may be arranged at a distance below the narrowed portion of the hearth 2.

[0023] During use of the gasifier, fuel is added at the top of the usually vertical inlet pipe 9. From this position the fuel passes downward into the inlet of the burner tube 1 having a slightly larger sectional area than the inlet pipe.

10 [0024] The burner tube 1 ends immediately above a narrowed portion of the sectional area which causes bridging. The bridging prevents the downward flow of the fuel material. The narrowed portion, which hereafter is referred to as a hearth 2, includes a material resistant to high temperatures, which for instance can be made of fire resistant bricks or brickwork.

15 [0025] The burner tube 1 and the hearth 2 typically each have a circular, horizontal cross section but also other suitable geometrical shapes are possible. Particularly the hearth 2 may have different shapes. It is only vital that the inner cavity of the hearth is downwardly narrowed having dimensions enabling bridging of the selected fuel. Thus in addition to providing the hearth with a circular, horizontal cross section, the hearth may be provided with a rectangular or square horizontal cross section. The hearth can also be provided with several openings such that the hearth for instance has the appearance of a grate with several openings, each dimensioned so as to enable bridging across each opening. Similarly, a hearth provided with several circularly or squarely shaped openings is also possible, each opening being dimensioned so as to enable bridging across said opening.

20 [0026] The inner cavity of the hearth is confined by its inner wall or walls. The number and shape of the wall or walls can vary, *inter alia* in relation to the degree of planeness/curvature and the angle in relation to vertical. As mentioned above it is important that the inner cavity of the hearth is downwardly narrowed to enable bridging. The dimensions of the hearth are also to be adjusted to the dimensions of the fuel used in order to enable bridging. It is also preferred that the height of the hearth is such that the heating zone relevant remains substantially enclosed by the walls of the hearth.

25 [0027] The amount of fuel added is controlled by building-up and maintaining a certain level of fuel in the burner tube. The fuel level is detected by a sensor, not shown, based on for instance a mechanical or electronic function. The signal of the sensor is used for controlling the fuel supply.

30 [0028] In addition to the feeding of fuel at the top of the burner tube, primary air, preferably pre-heated, is fed at the same location through the inlet 11 concurrent to the movement of the fuel. In the upper portion of the burner tube where solid, moderately flowable biofuel is in a free fall, the primary air passes through the pipe downward at uniform speed and is distributed over the entire cross section.

35 [0029] The air then continues downward inside the burner tube through a first zone of the fixed and yet unreacted biofuel being retained on top of the hearth 2 due to its limited flowability. The biofuel is dried during the passage of air in the first zone.

40 [0030] At the end of the first zone, the biofuel is sufficiently dry to cause its temperature to rise. In the initial stage of the second zone, the biofuel reacts with air in flaming pyrolysis. In this second zone, volatile gases, wood oils and tar compounds are expelled from the biofuel and burn during the formation of CO₂ and H₂O, thus supplying heat to the pyrolysis process. It is preferable that the flaming pyrolysis in the second zone is optimally concentrated immediately below the mouth of the burner tube 1. In order to ensure that a sufficient amount of air is present at this position in the zone to generate heat for maintaining the pyrolysis process in this position, additional, usually pre-heated-air, referred to as secondary air, may be supplied through a variable valve 10 through the inlet 12 on the outer face of the burner tube 1. This secondary air enters directly into the zone involving the flaming pyrolysis below the mouth of the burner tube.

45 [0031] In the last part of the second zone, when the oxygen has been consumed, H₂ and CO are formed during continuous pyrolysis and the biofuel is converted into charcoal.

[0032] The charcoal formed has obtained such a flowability that it partly due to gravity and partly by way of the downward flow of gas leaves its position on top of the hearth 2 and falls through the vertical opening of the hearth and ends on a subjacent grate 3 forming a third zone.

50 [0033] In the third zone the process is an adiabatic charcoal gasification process where the hot gases formed during the pyrolysis are led down through the charcoal layer, where the gas reacts with the charcoal under the formation of additional CO and H₂. The reactions converting the solid charcoal to CO and H₂ in this zone are endothermic processes consuming heat from the gas per se.

55 [0034] The heat of the gas and of the solid charcoal is thus converted into chemically bound energy in the gas generated by the fuel, in the following referred to as product gas, the temperature dropping to approx. 800 °C. Below this temperature the process progresses very slowly. Finally, the remaining ash and the unreacted charcoal drop down through slits and/or holes in and between elements making up the grate. The ash is collected in a mechanical ash

conveyance system 4 and 8 leading the ash to the surroundings through a gas-proof gate 5. In Fig. 1 the gas-proof gate is designed as a water trap 5.

[0035] The product gas generated is also recovered through the bottom grate 3 to the compartment 13 via the ash conveyance system and is then led out of the compartment through the pipe 7. The chemically bound energy of the product gas can subsequently to purification in for instance a cyclone be utilised in a gas combustion process.

The hearth structure

[0036] A correct dimensioning of the hearth is vital in order for the hearth to control the transition of the fuel from the second zone to the third zone such that the vertical position of the zones remain stable.

[0037] When dimensioning the hearth it should be ensured that its shape enables an advantageous bridging of the non-charred, moderately flowable fuel across the hearth. In order to obtain this effect, the characteristic physical properties of the particular fuel determining flowability of the fuel should be considered. The relevant properties which can be described as physically measurable parameters, are *inter alia*:

- a) The bridging tendency of the fuel
- b) The angle of the fuel in relation to a horizontal base when the fuel runs out through a hole in the bottom of a flat-bottomed vessel after the fuel flow has ceased. This angle is here referred to as the angle of repose.
- c) The friction of the fuel against different bases which may support or abut the fuel, e.g. fire-proof materials.

[0038] Methods of determining the tendency for bridging of different wood fuel types are described in *inter alia* "Trådbränselns hanteringsegenskaber - benägenhet til valvbinding för olika sortiment. Jan Erik Mattson. Sveriges Lantbruksuniversitet. Report No 181, Garpenberg 1989" in which also results of measurements of bridging of different wood fuels can be found.

[0039] "Trådbränselns hanteringsegenskaber - rasvinkler för olika sortiment. Jan Erik Mattson, Sveriges Lantbruksuniversitet. Report No 179 Garpenberg 1989" mentions different definitions and methods of determining the angle of repose of different wood fuel types. Results of measurements of angles of repose based on one of the methods can also be found therein.

[0040] "Trådbränselns hanteringsegenskaber - friktion mellan olika underlag och bränslesortiment. Jan Erik Mattson. Sveriges Lantbruksuniversitet. Report No 180 Garpenberg 1989" discloses results of measurements of friction for different types of wood fuel against different bases.

[0041] In the embodiment shown in Fig. 2 the hearth is shaped as a conical inlet 20 of a truncated cone-shape passing the fuel vertically downward into a cylindrical channel 21 allowing charcoal and pyrolysis gases to continue down into the reduction zone.

[0042] The truncated cone forms a characteristic angle α in relation to the horizontal plane and opens into a characteristic diameter D shown in Fig. 2.

[0043] When dimensioning the hearth, the diameter D is chosen in relation to the bridging tendency of the fuel and the charcoal. The dimension is thus determined to effect bridging of the unreacted, moderately flowable fuel, but not of the subsequently formed charcoal having improved flowability.

[0044] Similarly, the angle α is determined by the angle of repose and friction of the fuel against the base. The dimension α has to ensure that the unreacted fuel does not fall down, until after being converted to charcoal.

Partial oxidation

[0045] According to a preferred embodiment of the process according to the invention the fuel material passes between the combustion zone (c) and the reduction zone (d) through a partial oxidation zone involving partial oxidation of gas and tar substances. This is ensured by adding a gasification agent through the inlets 6.

[0046] According to this embodiment, the gasifier is thus provided with an additional option for adding gasification agents through the hearth via the inlets 6. The gasification agent serves to produce a much more pure gas and to further stabilise the zones. The added gasification agent can be air, water vapour, CO₂ or any mixtures thereof. During operation the air intake can be adjusted continuously to the desired amount by means of a valve (not shown) or the air intake can be completely shut-off at this point.

[0047] The additional supply of gasification agent occurs in the transition between the second zone and third zone inside the hearth, where the charcoal passes downward to the grate 3 in free fall. This third supply of gasification agent, e.g. air, occurs via a set of channels 6 ending into the vertical gas channel 21 in the hearth, through which gas and charcoal drop from the second zone to the third zone. As a result a zone involving partial oxidation is established at this position, said zone in the following being referred to as zone 2 $\frac{1}{2}$.

[0048] The air supplied in zone 2 $\frac{1}{2}$ is mixed with the downwardly flowing pyrolysis gases over the entire cross-section

of the hearth and thereby causing a partial combustion of the pyrolysis gases. The partial oxidation causes the majority of the formed tar substances from the pyrolysis zone to decompose and the temperature of the product gas to rise to above 1000 °C in this zone. By supplying air to a position in which the fuel is in a free fall the unpyrolysed material is prevented from moving from the conical inlet of the hearth 20 and down to the reduction zone without having been into contact with oxygen. Thus, the air intake in zone 2½ causes a significant rise in the temperature of the product gas, whereby the charcoal conversion is increased in the subsequent third zone, wherein the reactions are endothermic.

[0049] Tests in which the process and gasifier according to the invention have been used, have shown that a surprisingly good stability is obtained even when a comparatively small gasifier is used. This is especially surprising when considering that complicated control of the temperature, primary air and secondary air based on temperature measurements on several levels have been necessary in previous processes.

[0050] Without restricting the invention to a particular theoretical explanation, a hypothetical explanation of the stability obtained by designing the hearth in accordance with the present invention is provided below.

[0051] In order to ensure a stable process during operation it is required that the conversion of charcoal in the third zone (the reduction zone) proceeds at the same speed as the production of charcoal in the flaming pyrolysis zone. Preferably the height of the charcoal in the third zone is as constant as possible.

[0052] A number of parameters determine the conversion process in the reduction zone *inter alia*: the insulation of the gasifier, the water content in the fuel, the gas temperature prior to the reduction zone.

[0053] If the charcoal is consumed more rapidly during the reduction processes than the production of charcoal in the flaming pyrolysis zone, the charcoal height decreases.

[0054] Within a period of time all the charcoal will be completely consumed and the reduction zone completely gone. By not providing a hearth to effect bridging, the flaming pyrolysis zone moves downward toward the grate and the flames burn through the holes and channels of the grate. As a result the pyrolysis gases, having a low burning value and containing large quantities of tar substances, are passed directly out of the gasifier, which is not desirable.

[0055] If on the contrary the charcoal production in the pyrolysis zone exceeds the charcoal conversion in the reduction zone, it will result in increased charcoal height in the reduction zone.

[0056] Without the provision of a hearth, the flaming pyrolysis zone is then pushed upwards resulting in a rise of the other zones. This would probably result in the flaming pyrolysis zone being "squeezed" in between the drying zone, which is to be completed before the flaming pyrolysis zone can commence, and the reduction zone.

[0057] At varying loads of the gasifier and at varying fuels parameters, the positions of the zones are expected to move upwards and downwards. This is prevented by the hearth interrupting the connection between the zones to prevent them from affecting each other.

[0058] According to the preferred embodiment, in which a zone involving partial oxidation, zone 2½, is established, the fuel height may be kept constant by means of the hearth and by supplying a correct amount of air to zone 2½ as well as by adjusting the physical dimensions of the drying zone, pyrolysis zone and combustion zone in relation to the physical dimensioning of the reduction zone.

[0059] Initially, the hearth, the flaming pyrolysis zone and the reduction zones are dimensioned in order to provide a state in which the charcoal height in the reduction zone has a tendency to rise slowly in time.

[0060] However, during operation the air intake in the partial oxidation zone causes the top of the charcoal layer to be burned in the flames of the partial oxidation zone, when the charcoal top approaches the position of the air nozzles in the hearth. If the charcoal nevertheless becomes up-close to the air nozzles, it is assumed that the air not only reacts with the gas and the tar substances but also begins to react directly with the charcoal in a combustion process thereby producing CO₂ and H₂O as well as heat.

[0061] As a result the increase in the charcoal height is slowed down prior to reaching the point at which it abuts the flaming pyrolysis zone taking place in the bridging on the hearth. Thus the hearth and the air intake have two essential functions, i.e. to act as a physical barrier between the two zones and to establish a free space - a freeboard - for the burning in the partial oxidation zone, where gas and tar substances are reacted.

Example

[0062] In the present example, a gasifier is used as shown in Figs. 1 and 2. The diameter of the burner tube 1 is 350 mm. The hearth 2 is made of a fireproof ceramic material. The angle of the truncated cone a is 30 ° and the diameter D of the cylindrical channel 21 is 100 mm.

[0063] The fuel used is dried whole-tree chips of a conventional quality, where the largest dimensions of the individual chips range between 10 and 50 mm. During the test, the fuel height is set at approx. 500 mm measured from the lower end of the burner tube 1.

[0064] A test has been carried out to assess the stability of the gasification process. Thus, it was examined whether it would be possible to operate continuously for 100 hours which was achieved in the first test. During the test, an engine, in which the gas produced was used as fuel, was able to run continuously for 84 hours. The added chip amount

EP 1 442 101 B1

was 40 kg per hour and a product gas was produced having a burning value of 4.3 MJ/m³_n (dry gas) in an amount of 92 m³_n per hour (dry gas).

[0065] The stability of the stratified process was confirmed by means of temperature detectors. At different times during the test, low dust and tar values were measured in the raw product gas. The measured values appear from the table below.

Measurement period (hours after start)	dust in raw product gas (mg/m ³ _n)	tar in raw product gas (mg/m ³ _n)
28.5-29.5	71	57
32.5-33.5	158	111
81-82	170	130
98.75-99.75	142	162

[0066] The above description of the invention reveals that it is obvious that it can be varied in many ways. Such variations are not to be considered a deviation from the scope of the invention, and all such modifications which are obvious to persons skilled in the art are also to be considered comprised by the scope of the succeeding claims.

Claims

1. A process for gasification of solid, moderately flowable biofuel in a downdraft gasifier having an open core and a fixed gasification bed wherein the fuel material and primary air are fed at the top so as from the top and downward to pass

- a) a drying zone
- b) a pyrolysis zone
- c) a combustion zone involving flaming pyrolysis to which secondary air is fed, and where the fuel is supported by way of a narrowed portion in the inner cross section of the gasifier,
- d) a reduction zone, and
- e) optionally an inactive charcoal zone,

characterised by retaining the fuel material by means of the narrowed portion in the flaming pyrolysis zone (c) through bridging across the opening or openings of the narrowed portion until the material as a result of the partial combustion has been converted into a material in the form of charcoal, having such a flowability that it resumes the downward movement towards the reduction zone, whereby a separation of the combustion zone and the reduction zone is ensured, the reduction zone being located under the narrowed portion in the inner cross section of the gasifier.

2. A process according to claim 1, **characterised in that** the fuel material between the combustion zone (c) and the reduction zone (d) passes a partial oxidation zone involving a partial oxidation of gas and tar substances, and where a gasification agent is added in the oxidation zone.

3. A process according to claim 2, **characterised in that** the gasification agent is oxygen, water vapour, CO₂ or a mixture thereof.

4. A process according to claim 1, **characterised in that** the fuel material is a combustible organic material in form of solid, relatively small pieces of material of suitably uniform sizes.

5. A process according to claim 4, **characterised in that** the fuel material is wood chips, shavings, saw dust or compressed wood pellets.

6. A downdraft gasifier having an open core and a fixed gasification bed for the gasification of a solid, moderately flowable biofuel, said gasifier including a reactor having an opening at the top for feeding fuel material and primary air in the following sequence from the top and downward to

- a) a drying zone

- b) a pyrolysis zone
- c) a combustion zone involving flaming pyrolysis and having an opening for feeding secondary air and a narrowed portion in the inner cross section of the gasifier,
- d) a reduction zone, and
- e) optionally an inactive charcoal zone,

and a collecting compartment at the bottom of the gasifier having means for removing ash and the fuel gas resulting from the gasification, respectively,

characterised in that the narrowed portion in the flaming pyrolysis zone (c) is a hearth having one or more openings dimensioned relative to the biofuel used in such a manner that the fuel material is retained through bridging across the opening or openings of the hearth until the material as a result of the partial combustion has been converted into a material in the form of charcoal, having such a flowability that it resumes the downward movement towards the reduction zone, whereby a separation of the combustion zone and the reduction zone is ensued, the reduction zone being located under the narrowed portion in the inner cross section of the gasifier.

7. A downdraft gasifier according to claim 6, **characterised in that** an opening is provided after the narrowed portion in the flaming pyrolysis zone (c) and before the reduction zone (d) for feeding the gasification agents.

8. A downdraft gasifier according to any of the claims 6 to 7, **characterised in that** the hearth has a single opening formed as a truncated cone downwardly ending in a cylindrical channel or that the hearth has a single opening formed as a slot downwardly ending in a rectangular channel.

9. A downdraft gasifier according to any of the claims 6 to 7, **characterised in that** the hearth has more than one opening.

10. A downdraft gasifier according to claim 9, **characterised in that** the openings of the hearth are formed as a grate or **in that** the hearth is provided with openings of a circular or square horizontal cross section.

11. A plant for heat or a combined heat and power production including a downdraft gasifier according to any of the claims 6-10.

Patentansprüche

1. Verfahren zum Vergasen eines festen, mäßig fließfähigen Biokraftstoffs in einem Fallstromvergaser ("downdraft gasifier") mit einem offenen Kern und einem fixierten Vergasungsbett, wobei das Kraftstoffmaterial und Primärluft oben zugeführt werden, um von oben nach unten zu durchlaufen

- a) eine Trocknungszone
- b) eine Pyrolysezone
- c) eine Verbrennungszone mit Flammpyrolyse, der Sekundärluft zugeführt wird, und wobei der Kraftstoff mittels eines verengten Teils im inneren Querschnitt des Vergasers getragen wird,
- d) eine Reduktionszone und
- e) fakultativ eine inaktive Holzkohlenzone,

dadurch gekennzeichnet, daß das Kraftstoffmaterial mittels des verengten Teils in der Flammpyrolysenzone (c) durch Überbrückung zwischen der Öffnung oder den Öffnungen des verengten Teils gehalten wird, bis das Material als ein Ergebnis der partiellen Verbrennung in ein Material in der Form von Holzkohle mit einer solchen Fließfähigkeit umgewandelt worden ist, daß es die Bewegung nach unten zur Reduktionszone hin aufnimmt, wobei eine Trennung der Verbrennungszone und der Reduktionszone sichergestellt ist, wobei sich die Reduktionszone unterhalb des verengten Teils im inneren Querschnitt des Vergasers befindet.

2. Verfahren nach Anspruch 1, **dadurch gekennzeichnet, daß** das Kraftstoffmaterial zwischen der Verbrennungszone (c) und der Reduktionszone (d) eine partielle Oxidationszone durchläuft, die eine partielle Oxidation von Gas- und Teersubstanzen beinhaltet, und wobei ein Vergasungsmittel in der Oxidationszone zugegeben wird.

3. Verfahren nach Anspruch 2, **dadurch gekennzeichnet, daß** das Vergasungsmittel Sauerstoff, Wasserdampf, CO₂ oder eine Mischung davon ist.

EP 1 442 101 B1

4. Verfahren nach Anspruch 1, **dadurch gekennzeichnet, daß** das Kraftstoffmaterial ein brennbares organisches Material in Form von festen relativ kleinen Stücken von Material mit geeignet uniformen Größen ist.

5. Verfahren nach Anspruch 4, **dadurch gekennzeichnet, daß** das Kraftstoffmaterial Holzscheibchen ("wood chips"), Späne, Sägestaub oder komprimierte Holzpellets ist.

6. Fallstromvergaser ("downdraft gasifier") mit einem offenen Kern und einem fixierten Vergasungsbett zum Vergasen eines festen, mäßig fließfähigen Biokraftstoffs, wobei besagter Vergaser einen Reaktor mit einer Öffnung oben zum Zuführen von Kraftstoffmaterial und Primärluft in der folgenden Abfolge von oben nach unten

a) einer Trocknungszone

b) einer Pyrolysezone

c) einer Verbrennungszone mit Flammpyrolyse und mit einer Öffnung zum Zuführen von Sekundärluft und einem verengten Teil im inneren Querschnitt des Vergasers

d) einer Reduktionszone und

e) fakultativ einer inaktiven Holzkohlenzone

und ein Sammelabteil am Boden des Vergasers mit Mitteln zum Entfernen von Asche bzw. des Kraftstoffgases beinhaltet, das aus der Vergasung resultiert,

dadurch gekennzeichnet, daß der verengte Teil in der Flammpyrolysenzone (c) ein Herd mit einer oder mehreren Öffnungen ist, die im Verhältnis zu dem verwendeten Biokraftstoff auf eine solche Weise dimensioniert sind, daß das Kraftstoffmaterial durch eine Überbrückung zwischen der Öffnung oder den Öffnungen des Herdes zurückgehalten wird, bis das Material als ein Ergebnis der partiellen Verbrennung in ein Material in der Form von Holzkohle mit einer solchen Fließfähigkeit umgewandelt worden ist, daß es die Bewegung nach unten zur Reduktionszone hin aufnimmt, wobei eine Trennung der Verbrennungszone und der Reduktionszone sichergestellt ist, wobei sich die Reduktionszone unterhalb des verengten Teils im inneren Querschnitt des Vergasers befindet.

7. Fallstromvergaser gemäß Anspruch 6, **dadurch gekennzeichnet, daß** eine Öffnung hinter dem verengten Teil in der Flammpyrolysenzone (c) und vor der Reduktionszone (d) zum Zuführen der Vergasungsmittel bereitgestellt ist.

8. Fallstromvergaser nach einem der Ansprüche 6 bis 7, **dadurch gekennzeichnet, daß** der Herd eine einzelne Öffnung hat, die als ein trunkierter Konus gebildet ist, der nach unten in einem zylindrischen Kanal endet, oder daß der Herd eine einzelne Öffnung hat, die als ein Schlitz gebildet ist, der nach unten in einem rechtwinkligen Kanal endet.

9. Fallstromvergaser nach einem der Ansprüche 6 bis 7, **dadurch gekennzeichnet, daß** der Herd mehr als eine Öffnung hat.

10. Fallstromvergaser nach Anspruch 9, **dadurch gekennzeichnet, daß** die Öffnungen des Herdes als ein Gitter gebildet sind, oder daß der Herd mit Öffnungen mit einem zirkulären oder rechtwinkligen horizontalen Querschnitt ausgestattet ist.

11. Anlage zur Erzeugung von Wärme oder Wärme und Energie in Kombination, einschließlich eines Fallstromvergasers nach einem der Ansprüche 6-10.

Revendications

1. Procédé de gazéification d'un biocombustible solide, ayant une aptitude modérée à l'écoulement, dans un gazéifieur à tirage par en bas, ayant un coeur ouvert et un lit de gazéification fixe, en tête duquel sont introduits le matériau combustible et de l'air principal, de manière qu'ils traversent, du haut vers le bas,

a) une zone de séchage,

b) une zone de pyrolyse,

c) une zone de combustion mettant en jeu une pyrolyse à la flamme, dans laquelle est introduit un air secondaire, et dans laquelle le combustible est porté au moyen d'une partie rétrécie formée dans la section trans-

EP 1 442 101 B1

versale interne du gazéifieur,

d) une zone de réduction, et

5 e) éventuellement, une zone de charbon inactif,

caractérisé par l'opération qui consiste à retenir le matériau combustible dans la zone de pyrolyse à la flamme (c), grâce à la partie rétrécie, à travers un pont formé au-dessus de la ou des ouvertures de la partie rétrécie, jusqu'à ce que le matériau ait été converti, en conséquence de la combustion partielle, en un matériau se présentant sous la forme de charbon, ayant une aptitude à l'écoulement telle qu'il reprend son chemin vers le bas, vers la zone de réduction, ce qui assure une séparation entre la zone de combustion et la zone de réduction, la zone de réduction étant située en dessous de la partie rétrécie formée dans la section transversale interne du gazéifieur.

15 2. Procédé selon la revendication 1, **caractérisé en ce que** le matériau combustible, entre la zone de combustion (c) et la zone de réduction (d), traverse une zone d'oxydation partielle mettant en jeu une oxydation partielle de substances gazeuses et du type goudron, zone d'oxydation dans laquelle est ajouté un agent de gazéification.

20 3. Procédé selon la revendication 2, **caractérisé en ce que** l'agent de gazéification est de l'oxygène, de la vapeur d'eau, du CO₂ ou un mélange de ceux-ci.

4. Procédé selon la revendication 1, **caractérisé en ce que** le matériau combustible est un matériau organique combustible se présentant sous la forme de morceaux de matériaux solides, relativement petits, d'une taille uniforme appropriée.

25 5. Procédé selon la revendication 4, **caractérisé en ce que** le matériau combustible comprend des particules de bois, des copeaux, de la sciure ou des pastilles de bois densifiées.

30 6. Gazéifieur à tirage par en bas, ayant un coeur ouvert et un lit de gazéification fixe, pour la gazéification d'un biocombustible solide, ayant une aptitude modérée à l'écoulement, ledit gazéifieur comprenant un réacteur en tête duquel est aménagée une ouverture pour l'alimentation en matériau combustible et en air principal, dans la séquence suivante du haut vers le bas,

35 a) d'une zone de séchage,

b) d'une zone de pyrolyse,

c) d'une zone de combustion mettant en jeu une pyrolyse à la flamme, et ayant une ouverture pour l'introduction d'air secondaire et une partie rétrécie formée dans la section transversale interne du gazéifieur,

d) d'une zone de réduction, et

e) éventuellement, d'une zone de charbon inactif,

40 et un compartiment de récupération, en queue du gazéifieur, ayant des moyens servant à retirer respectivement la cendre et le gaz combustible résultant de la gazéification,

caractérisé en ce que la partie rétrécie dans la zone de pyrolyse à la flamme (c) est un creuset ayant une ou plusieurs ouvertures dimensionnées en fonction du biocombustible utilisé, de telle sorte que le matériau combustible soit retenu à travers un pont formé au-dessus de la ou des ouvertures du creuset, jusqu'à ce que le matériau ait été converti, en conséquence de la combustion partielle, en un matériau se présentant sous la forme de charbon, ayant une aptitude à l'écoulement telle qu'il reprend son chemin vers le bas, vers la zone de réduction, ce qui assure une séparation entre la zone de combustion et la zone de réduction, la zone de réduction étant située en dessous de la partie rétrécie formée dans la section transversale interne du gazéifieur.

50 7. Gazéifieur à tirage par en bas selon la revendication 6, **caractérisé en ce qu'**une ouverture est aménagée après la partie rétrécie dans la zone de pyrolyse à la flamme (c) et avant la zone de réduction (d), pour l'introduction des agents de gazéification.

55 8. Gazéifieur à tirage par en bas selon l'une quelconque des revendications 6 ou 7, **caractérisé en ce que** le creuset a une seule ouverture ayant la forme d'un tronc de cône se terminant vers le bas en un canal cylindrique, ou **en ce que** le creuset a une seule ouverture ayant la forme d'une fente se terminant vers le bas en un canal rectangulaire.

EP 1 442 101 B1

9. GazéfiEUR à tirage par en bas selon l'une quelconque des revendications 6 ou 7, **caractérisé en ce que** le creuset a plus d'une ouverture.

5 10. GazéfiEUR à tirage par en bas selon la revendication 9, **caractérisé en ce que** les ouvertures du creuset ont la forme d'une grille, ou **en ce que** le creuset est pourvu d'ouvertures de section transversale horizontale circulaire ou carrée.

10 11. Installation pour la production de chaleur ou de chaleur et de puissance combinées, incluant un gazéfiEUR à tirage par en bas selon l'une quelconque des revendications 6 à 10.

15

20

25

30

35

40

45

50

55

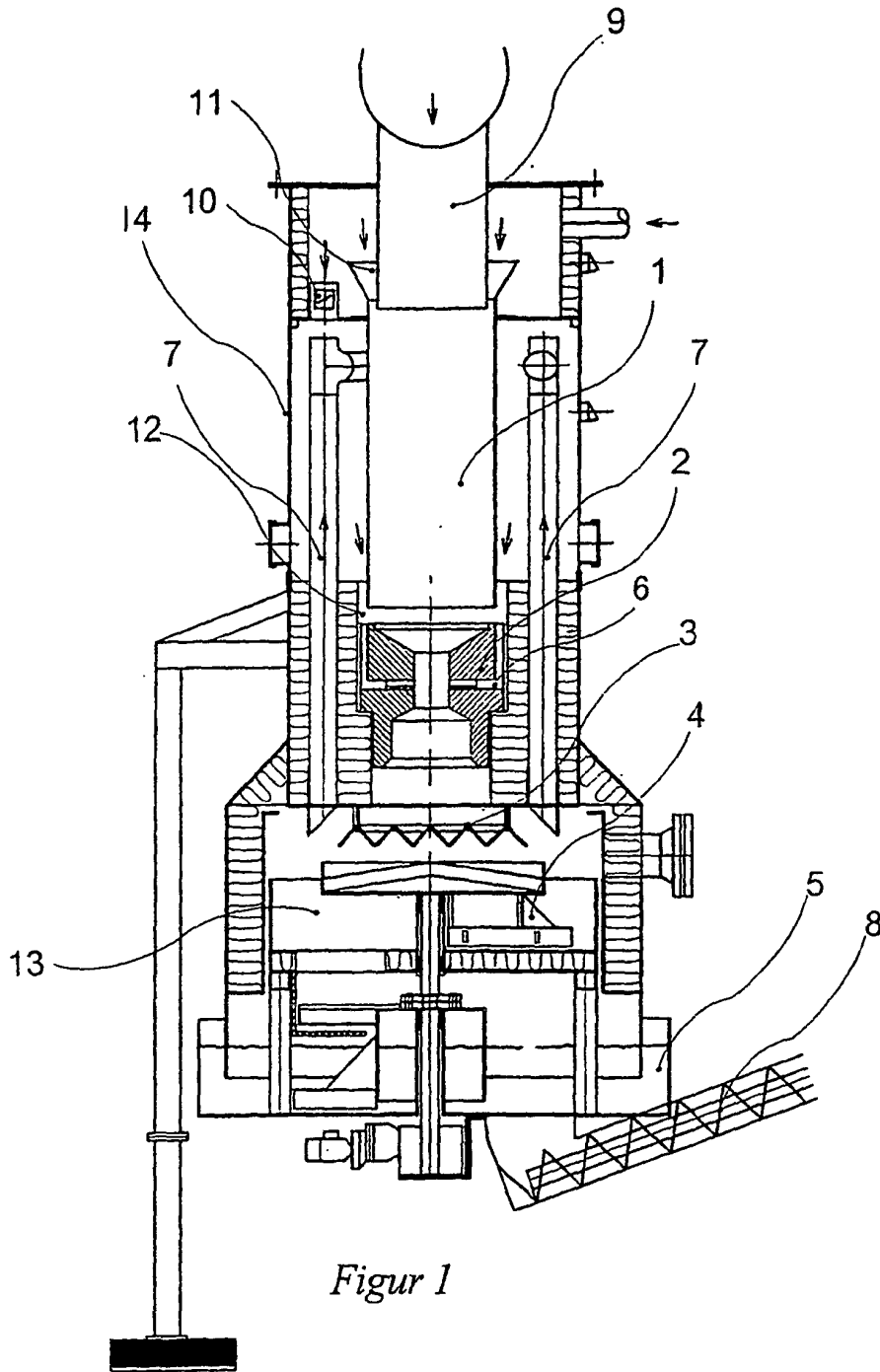

Figur 1

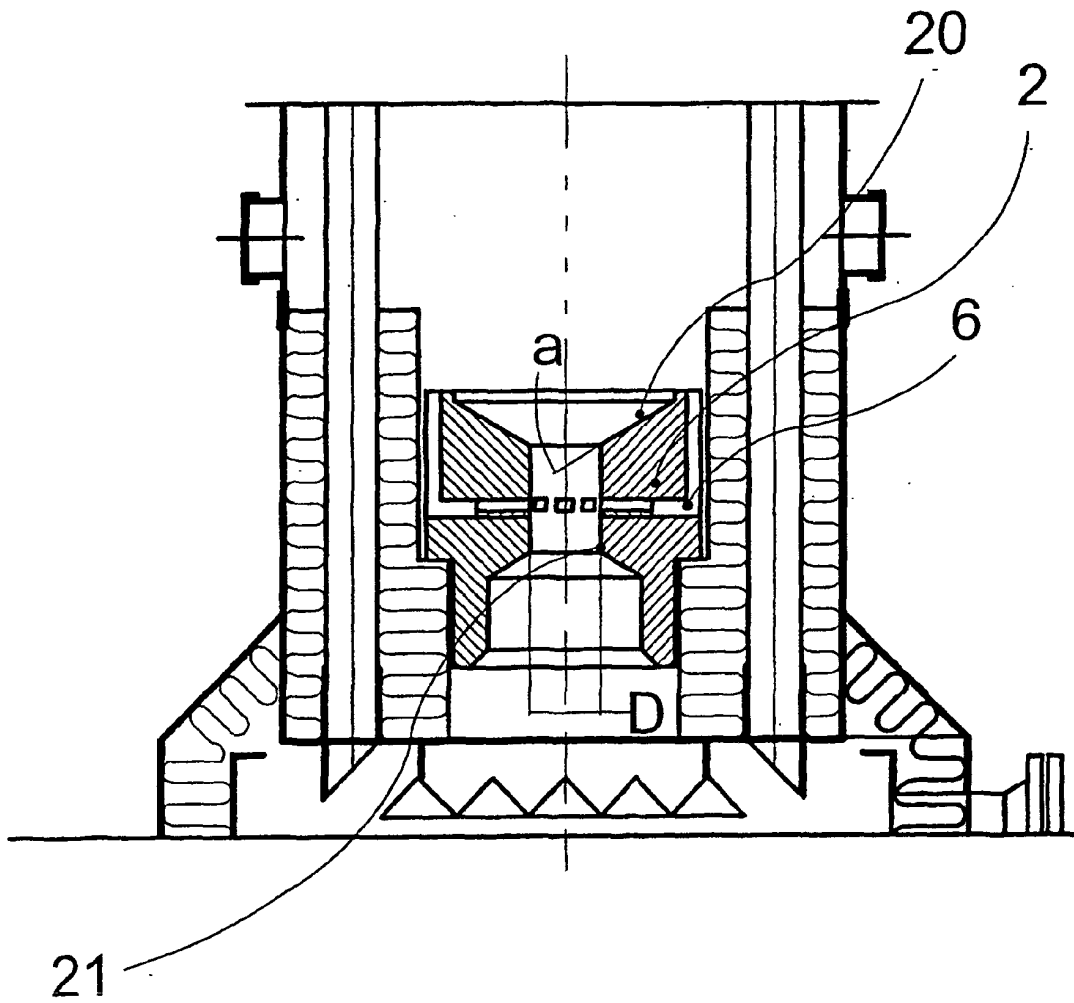

Figure 2